

PLATE CT25  
 R 7 1/4" x 3/4" x 1'-0 5/8"  
 W/(4) 7/8" Ø HOLES  
 FOR (4) 3/4" Ø x 3" A-325-N BOLTS  
 @ 3 1/2" GAGE

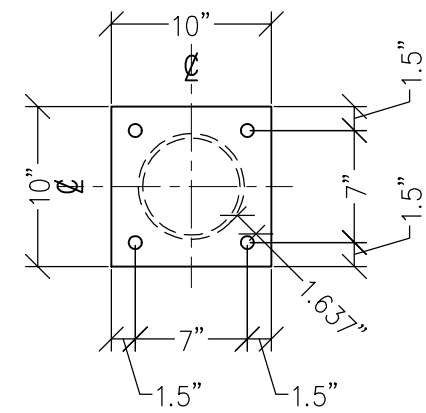

PLATE CB11A  
 R 3/4" x 10" x 0'-10"  
 W/(4) 1 3/16" Ø HOLES  
 FOR 3/4" Ø A.B. (EMBED 8")

**APPROVED FOR FABRICATION**

STEEL - U.N.O.		
TYPE OF MEMBER	ASTM SPEC.	F <sub>y</sub>
WIDE FLANGE SHAPES	A992	50 KSI
ALL OTHER SHAPES	A36	36 KSI
PLATE	A36 OR A572	36 KSI (MIN)
PIPE SECTIONS	A500 (GRADE B)	42 KSI
STRUCTURAL TUBING (SQ. OR RECT.)	A500 (GRADE B)	46 KSI
CONN. BOLTS	A307	36 KSI
HEADED SHEAR STUDS	A108	49 KSI
THREADED RODS	A36	36 KSI

**Paradise Ventures, Inc.**  
 P.O. Box 2441  
 Wenatchee, WA 98807  
 509.670.9375 - FAX 881.2720

SHOP DRAWINGS  
**WENATCHEE QUALITY WELDING**  
 MOSES LAKE CMC CENTER  
 DWG: MOSES LAKE CIVIC CENTER.DWG

**COLUMN**

DRAWN BY: COOKIE  
 CHECKED BY:

DATE: 01-17-2011

**S16**