

PLAN VIEW

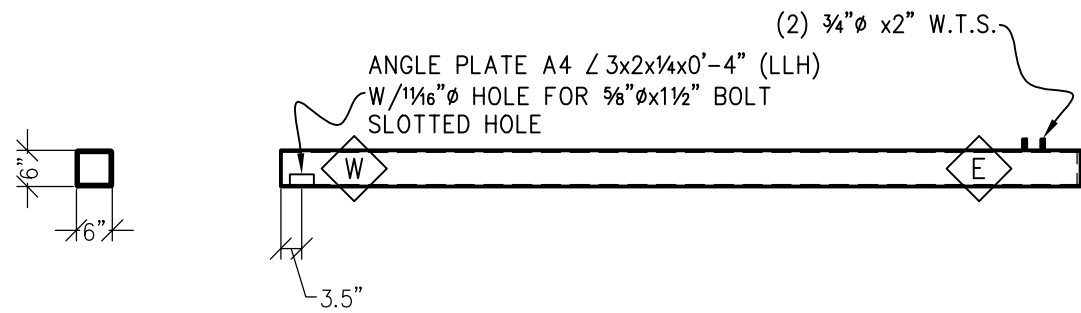

BEAM SE27 WELDED TO LOWER SIDE OF SE26

WEST END TO COL. S34
CONN. DETAIL 111/ST709

HSS6x6x5/16

EAST END TO COL. S42
CONN. DETAIL 110/ST708

BEAM SE26

SCALE: 3/8"=1'-0"

FABRICATE (1)

MK MARK ON BEAM

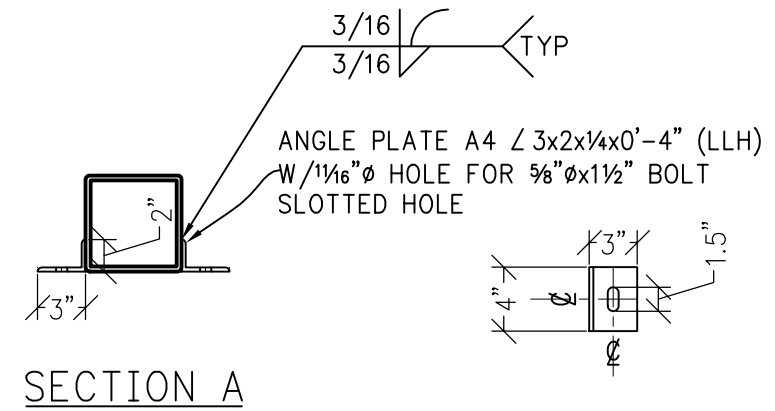

SECTION A

APPROVED FOR FABRICATION

STEEL - U.N.O.

TYPE OF MEMBER	ASTM SPEC.	F _y
WIDE FLANGE SHAPES	A992	50 KSI
ALL OTHER SHAPES	A36	36 KSI
PLATE	A36 OR A572	36 KSI (MIN)
PIPE SECTIONS	A500 (GRADE B)	42 KSI
STRUCTURAL TUBING (SQ. OR RECT.)	A500 (GRADE B)	46 KSI
CONN. BOLTS	A307	36 KSI
HEADED SHEAR STUDS	A108	49 KSI
THREADED RODS	A36	36 KSI

CANOPY BEAM

SHOP DRAWINGS
WENATCHEE QUALITY WELDING
MOSES LAKE CMC CENTER
DWG: MOSES LAKE CIVIC CENTER.DWG

Paradise Ventures, Inc.

P.O. Box 2441
Wenatchee, WA 98807
509.670.9375 - FAX 881.2720

DATE: 01-08-2011
DRAWN BY: COOKE
CHECKED BY: