

STOPLIGHT SWITCH

To remove **Operation P/202**

1. With the ignition switched off, disconnect the two cables from the stoplight switch.
2. Unhook the spring connecting the switch to the brake lever.
3. Remove the switch from the chassis bracket.

To refit **Operation P/204**

Reverse the removal procedure.

WINDSCREEN WIPER, LUCAS C.W.1

Description

Vehicles up to 170603494, 270600798 and 870600025

The wiper motor consists of a three-pole armature running in a two-pole shunt-wound field. The drive is taken from the motor spindle by a series of gears to a crank which converts the rotary motion of the armature into the reciprocating motion required by the wiper arm.

To remove **Operation P/206**

1. With the ignition switched off, disconnect the cables from the wiper motor.
2. Slacken the wiper arm fixing nut and tap sharply to release the collet, which clamps the arm on to the spindle; then remove the wiper arm and blade.
3. Remove the wiper motor from the windscreen panel.

To refit **Operation P/208**

Reverse the removal procedure, positioning the wiper arm on the spindle to give a suitable sweep on the windscreen.

To dismantle the motor **Operation P/210**

1. Remove motor (Operation P/206).
 2. Unscrew the two threaded fixing studs, which also secure the packing block and bearing assembly to the wiper. Remove the parking handle (Fig. P-46) and the wiper cover, which is secured by two screws.
 3. Unsolder the four connections from the tags on the brushgear assembly. Note the arrangement of these connections to ensure correct re-assembly. Open the tag by which the cable between the field coils is secured to the brushgear assembly. Hold back the brush springs with a bent piece of wire, and remove the brushes. By removing the two securing screws the complete brushgear assembly can be removed from the motor.
 4. Pull the armature out of the motor. Take care not to lose the fibre washer on its spindle. Withdraw the two field coil securing screws and remove the field coil assemblies from the motor body.
 5. Drive out the pin securing the spindle loading spring and washer. Remove the spindle from the motor side of the wiper.
 6. Withdraw the two screws securing the gearbox cover plate and remove the plate.
 7. Remove the split pin and washer securing the geared sector, and pull the sector and connecting rod out of the gearbox.
- NOTE:** Before doing this the sector and gear on the driving sleeve must be marked to ensure correct meshing on reassembly, otherwise the parking and wiping positions of the arm will be incorrect.
8. The driving sleeve, final gear and intermediate gear can now be pulled out of the gearbox.

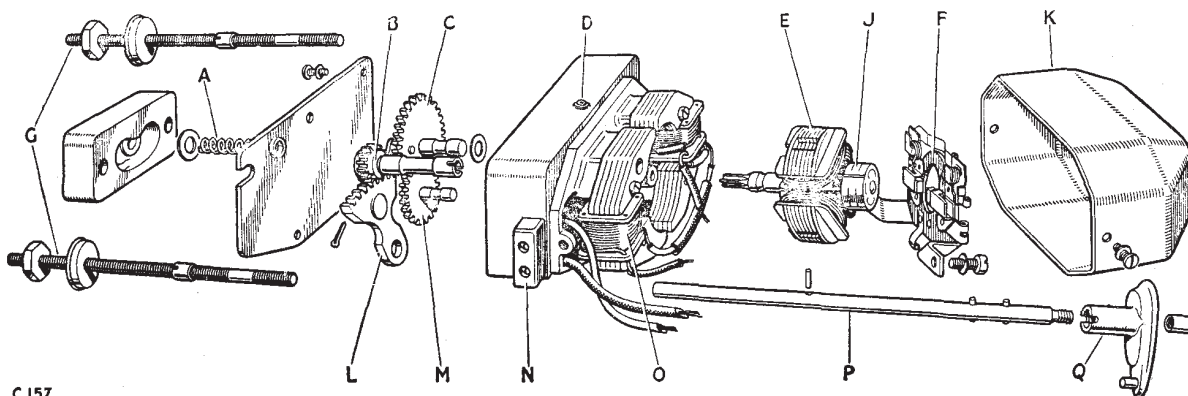

C.157

Fig. P-46—Windscreen wiper—type C.W.1.

- | | | | |
|--------------------------|--------------|---------------------|------------------|
| A—Spindle loading spring | E—Armature | K—Cover | O—Field coil |
| B—Driving sleeve | F—Brushgear | L—Geared sector | P—Spindle |
| C—Final gear | G—Stud | M—Intermediate gear | Q—Parking handle |
| D—Lubricator | J—Commutator | N—Terminal block | |

To assemble the motor **Operation P/212**

Reverse the dismantling procedure, observing the following points:—

- (a) See that the geared sector and the geared end of the driving sleeve are correctly engaged, according to the marks made on them when dismantling.
- (b) When refitting the field coil assemblies do not tighten the securing screws until the armature and brushgear have been refitted. There is a certain amount of play in the securing holes, by which the field coil assemblies can be adjusted so that there is no risk of their being fouled by the armature.
- (c) If the pin, by which the drive from the sleeve is transmitted to the wiper spindle, is worn or distorted so that the drive will not correctly engage, it should be tapped out and replaced by a short length of $\frac{1}{16}$ in. mild steel. If the corresponding slot in the driving sleeve is worn, the sleeve must be replaced.
- (d) Before refitting the gearbox cover plate, the gearbox must be packed with zinc oxide grease. A small amount of thin machine oil should be applied to the armature bearing lubricator.

WINDSCREEN WIPER, LUCAS F.W.2**Description**

Vehicles numbered 170603495, 270600799 and 87060026 onwards.

The wiper motor consists of a five-pole armature running in a single-pole wound field. Drive is transmitted from the armature spindle to an intermediate gear, then to a larger final drive gear with a crankpin fitted near the outer diameter. A connecting link fitted to the crankpin and a spindle sleeve, converts the rotary into reciprocating motion.

To remove **Operation P/214**

1. Slacken the wiper arm fixing nut and tap sharply to release the clamping collet, then remove the wiper arm and blade.
2. With the ignition switched off, disconnect the cables from wiper motor.
3. Remove the securing nuts, washers, grommets, wiper blade stop, rubber mounting block and brass bushes, then withdraw the motor.

To refit **Operation P/216**

1. Reverse removal procedure, but do not lock the wiper arm blade until the sweep is correctly adjusted.

To dismantle **Operation P/218**

1. Remove the circular nuts securing the mounting block to wiper motor body and withdraw the block (Fig. P-47).
2. Remove the parking lever and the cover securing screw, then withdraw the cover and unsolder the cable connecting the cover and brushgear terminals.

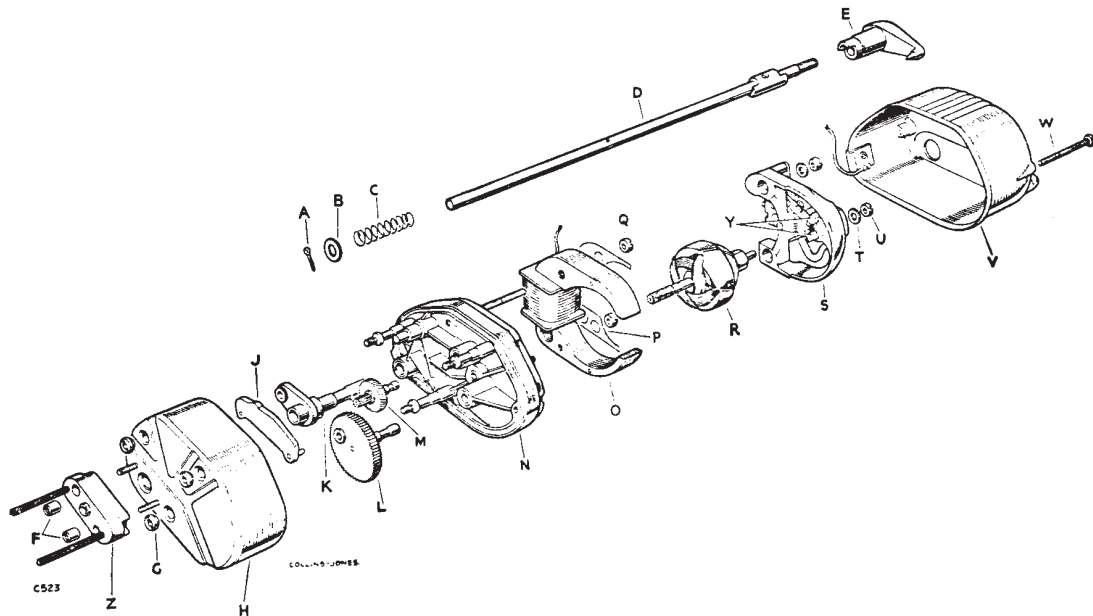

Fig. P-47—Windscreen wiper—type F.W.2.

A—Split pin	G—Circular cone seated nuts	N—Centre casing	T—Plain washer
B—Plain washer	H—Gearbox cover	O—Field	U—Circular nut
C—Spring	J—Connecting link	P—Gasket	V—Brushgear cover
D—Wiping spindle	K—Driving sleeve	Q—Securing nuts for field	W—Securing screws
E—Parking lever	L—Cranking gear	R—Armature	Y—Brushes
F—Circular nuts	M—Intermediate gear	S—Commutator-end bracket	Z—Packing plate

3. Unsolder the field coil cables from the brush terminals, remove the securing screws and locking washers, then withdraw the brushgear and armature bearing assembly. Ensure that the brushes are not inadvertently lost.
4. Withdraw the armature.
5. Remove the split pin securing the wiper shaft at the end extending from the wheel box and withdraw the plain washer, spring and then the shaft.
6. The field coil may be removed by unscrewing the nuts from the mounting studs; lift the coil, complete with paper packing, clear.
7. Unscrew the three securing nuts, withdraw the wheelbox cover, connecting link, driving sleeve, final and intermediate drive gears.

To assemble **Operation P/220**

1. Reverse dismantling procedure, observing the following points:
 - (a) Check the armature bearing in the main body for wear by locating the armature. It should not be possible for the laminated core to touch any part of the casing when moving sideways.
 - (b) Before finally tightening the field coil in position, locate the armature again in main body bush and ensure that an equal air gap exists between the armature core and field core. Adjust as necessary.
 - (c) If the commutator is badly scored, burnt or worn unevenly, mount the armature in a lathe and skim the surface of the commutator lightly with a sharp tool. Remove no more metal than is necessary and clean carefully between the commutator segments.
 - (d) Examine the brushes and replace if worn unduly.
 - (e) When fitting the brush holder and end bearing assembly, ensure that the armature and field core clearance is maintained and that the armature revolves freely after tightening the securing screws. The brushes can be kept sufficiently apart to clear the commutator by pressing the brush holders inward at the pivoting end.
 - (f) Zinc oxide grease must be smeared over the gears in wheel box, and a small surplus added to ensure efficient lubrication over a long period.

To fit the arms and blades **Operation P/222**

The wiper arm is fixed to the spindle by means of a collet, the hexagonal-headed nut serving to tighten the collet.

When fitting an arm, do not fully tighten the collet nut until the arm is positioned to wipe over the correct area of the screen and the blade lies unobtrusively at the edge of the screen when parked.

The blade is secured to the wiper arm by a tongue on the blade, which passes through a slot on the blade and is secured by a rubber bush.

To check a faulty wiper motor **Operation P/224**

If the wiper fails to operate, or operates unsatisfactorily, switch on the wiper and note the current being supplied to the motor, either on the instrument panel ammeter or, preferably, on a moving coil ammeter connected in the wiper circuit. Then proceed as follows:—

Wiper takes no current

Examine the fuse protecting the wiper circuit. If it has blown, examine the wiring of the wiper circuit and of all other circuits protected by the fuse for evidence of chafed cables or short circuits. Replace any cables that are badly worn or chafed, if necessary fitting protective sleeving over the cables to prevent a recurrence of the fault.

If the fuse is intact, disconnect the cables from the terminals of the wiper motor and connect the wiper direct to a battery of suitable voltage. Operation of the wiper under these conditions proves that there must be a broken cable or loose connection in the wiper circuit.

Remove the parking handle. Unscrew the two cover fixing screws and remove the cover of the wiper. See that the switch control moves freely, and that the brass contacting strips remain closed when the cover is removed; if they are dirty, clean them with fine emery cloth. Examine the wiring of the motor and resolder any connections that are loose or broken.

Wiper takes abnormally low current:

First ensure that the battery is not discharging and that all connections in the wiring to the wiper are clean and tight.

If the current is that normally taken by the field coils only (0.75 amperes) a fault in the armature, commutator or brushgear must be suspected.

See that the carbon brushes are clean and move freely in their holders. If the brush springs are weak, and do not hold the brushes firmly in contact with the commutator, new springs must be fitted. Remove the brushes and examine them; fit replacements if the brushes are badly worn. If the brushes are dirty or greasy clean them with a gasoline-moistened cloth.

Clean the commutator with a gasoline-moistened cloth, and carefully remove any carbon dust from between the segments. If the commutator is badly scored or burnt, remove the armature (see Operation P/218), mount it in a lathe and take a very light cut off the surface of the commutator with a sharp tool. Do not remove any more metal than is necessary, and take care to clean all metallic swarf and dust from the slots between the commutator segments.

The armature windings can be checked by removing the brushes from their holders and then measuring the resistance between two segments of the commutator. If the armature is in good condition this resistance should be within the limits given in Basic Plan Dimensions. The insulation between the commutator segments and the body of the wiper should also be checked.

If these tests prove the armature to be faulty it must be removed as described in Operation P/218 and a replacement fitted.

A similar procedure can be followed to check the field coils.

Wiper takes abnormally high current

The normal current consumption of the wiper lies between 1.8 and 2.5 amperes. If the current consumption as shown by the test ammeter is greatly in excess of this value, the armature windings, commutator or gearbox mechanism may be at fault.

First check that stiffness in the bearings or gearbox mechanism does not prevent the free rotation of the armature, if necessary dismantle the mechanism as described and renew any damaged components. Lubricate the armature spindle with a small quantity of thin machine oil.

Remove the cover of the wiper and examine the internal connections, brushgear and commutator for signs of a short circuit. See that a bent or damaged cover is not touching parts of the brushgear or wiring.

Clean the commutator, taking especial care to remove all traces of carbon or metallic dust from between the commutator segments.

Check the resistance of the armature and the field coils. If the resistance is appreciably below the figure given in Basic Plan Dimensions it is probable that the windings are at fault, and a new armature or field coil assembly must be fitted.

Wiper operates but does not drive the wiper arm

If the motor is heard to operate but does not drive the wiper arm, first ensure that the arm is firmly secured to the wiper spindle. Then dismantle the gearbox and drive mechanism as described in Operation P/218, renewing any faulty components.

TRAFFICATORS

To remove Operation P/226

1. Remove the brackets from the top of each windscreen side member by unscrewing the retaining screws.
2. Dismantle the trafficator (Fig. P-48) and remove the cables covered by a sheath (short cable from the trafficator for the driver's side).
3. Lower the instrument panel and disconnect the switch feed cable from the two-way connector on the green cable to the fuel gauge.

4. If it should be necessary to renew the trafficator cables, feed the cables from the trafficators through the holes just below where the brackets were attached, down the windscreen side members behind the rubber seal, from the sheath inside the hand rail and through the hole in the glove box top and disconnect from the switch.

5. To remove the switch bracket, unbolt the clamps securing it to the steering column.

NOTE: The trafficator switch may be either the self-cancelling or manual action type.

To refit

Operation P/228

Reverse the removal procedure, ensuring that sufficient slack is left in the trafficator cables between the windscreen and the hand rail to allow for folding of the windscreen.

FLASHING INDICATORS

To remove

Operation P/230

1. Remove the sidelights and disconnect all flasher cable harness.
2. Drop instrument panel to gain access to flasher unit and disconnect. Detach unit from dash.
3. Detach flasher cables from main harness and snap connector adjacent to stoplight switch.

NOTE: Wiring connection details are given under Operation P/232.

To refit

Operation P/232

1. Remove the instrument panel.
2. Make the following connections from the end of flasher harness having eight cables extending.
 - A Green and red cable to number 1 terminal on flasher switch.
 - B Red and green cable to number 4 terminal on flasher switch.
 - C Purple and green cable to number 5 terminal on flasher switch.
 - D Brown cable to number 12 terminal on flasher switch
 - E White and green cable to number 6 terminal on flasher switch.
 - F Green and white cable to number 13 terminal on flasher switch.
 - G Red cable to spring terminal on flasher warning light.
 - H Black cable to earth terminal on flasher warning light.
3. Connect the three cables extending 10 in. from flasher harness.
 - A Black cable to earth on speedometer.
 - B Red cable to terminal marked 'P' on flasher unit.
 - C Brown cable to terminal marked 'L' on flasher unit.