

THERMOSTAT (w/o DPF) > REMOVAL

THERMOSTAT (w/o DPF) > REMOVAL

for Preparation [Click here](#)

1. DISCONNECT CABLE FROM NEGATIVE BATTERY TERMINAL

NOTICE:

- After turning the ignition switch off, waiting time may be required before disconnecting the cable from the battery terminal. Therefore, make sure to read the disconnecting the cable from the battery terminal notice before proceeding with work ([Click here](#)).
- When disconnecting the cable, some systems need to be initialized after the cable is reconnected ([Click here](#)).

2. REMOVE FRONT BUMPER LOWER COVER

- Remove the clip, 5 bolts and front bumper lower cover.

3. REMOVE NO. 1 ENGINE UNDER COVER SUB-ASSEMBLY

- Remove the 4 bolts and No. 1 engine under cover.

4. DRAIN ENGINE COOLANT

CAUTION:

Do not remove the radiator cap while the engine and radiator are still hot. Pressurized, hot engine coolant and steam may be released and cause serious burns.

- Loosen the radiator drain cock plug.

HINT:

Collect the coolant in a container and dispose of it according to the regulations in your area.

- Drain the coolant by removing the reservoir cap and, using a wrench, remove the vent plug.

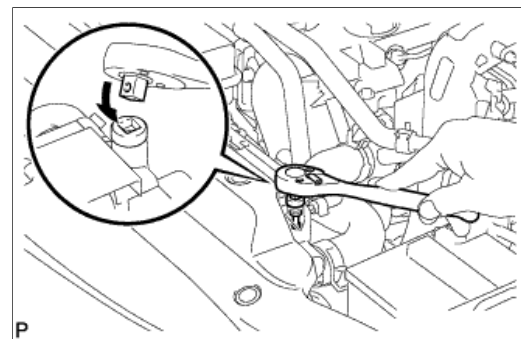

- Loosen the cylinder block drain cock plug.

- DISCONNECT CABLE FROM NEGATIVE BATTERY TERMINAL
- REMOVE FRONT BUMPER LOWER COVER
- REMOVE NO. 1 ENGINE UNDER COVER SUB-ASSEMBLY
- DRAIN ENGINE COOLANT
- REMOVE FRONT FENDER APRON SEAL RH
- REMOVE FRONT NO. 1 FENDER APRON TO FRAME SEAL RH
- REMOVE UPPER RADIATOR SUPPORT SEAL
- REMOVE FRONT HEATER BRACKET (for Cold Area Specification Vehicles)
- REMOVE FAN AND GENERATOR V BELT
- REMOVE NO. 1 AIR CLEANER HOSE
- REMOVE AIR CLEANER CAP SUB-ASSEMBLY
- REMOVE AIR CLEANER FILTER ELEMENT SUB-ASSEMBLY
- REMOVE AIR CLEANER CASE SUB-ASSEMBLY
- REMOVE NO. 1 AIR HOSE
- REMOVE COMPRESSOR OUTLET ELBOW
- REMOVE VISCOUS WITH MAGNET CLUTCH HEATER ASSEMBLY (for Cold Area Specification Vehicles)
- REMOVE VISCOUS HEATER NO. 1 BRACKET SUB-ASSEMBLY (for Cold Area Specification Vehicles)
- DISCONNECT COOLER COMPRESSOR ASSEMBLY (w/ Air Conditioning System)
- REMOVE GENERATOR BRACKET

- 20. REMOVE GENERATOR ASSEMBLY
- 21. REMOVE NO. 1 COMPRESSOR MOUNTING BRACKET
- 22. REMOVE VENTILATION PIPE
- 23. REMOVE ENGINE OIL LEVEL DIPSTICK GUIDE
- 24. DISCONNECT NO. 2 RADIATOR HOSE
- 25. DISCONNECT NO. 2 WATER BY-PASS HOSE
- 26. REMOVE WATER INLET
- 27. REMOVE THERMOSTAT

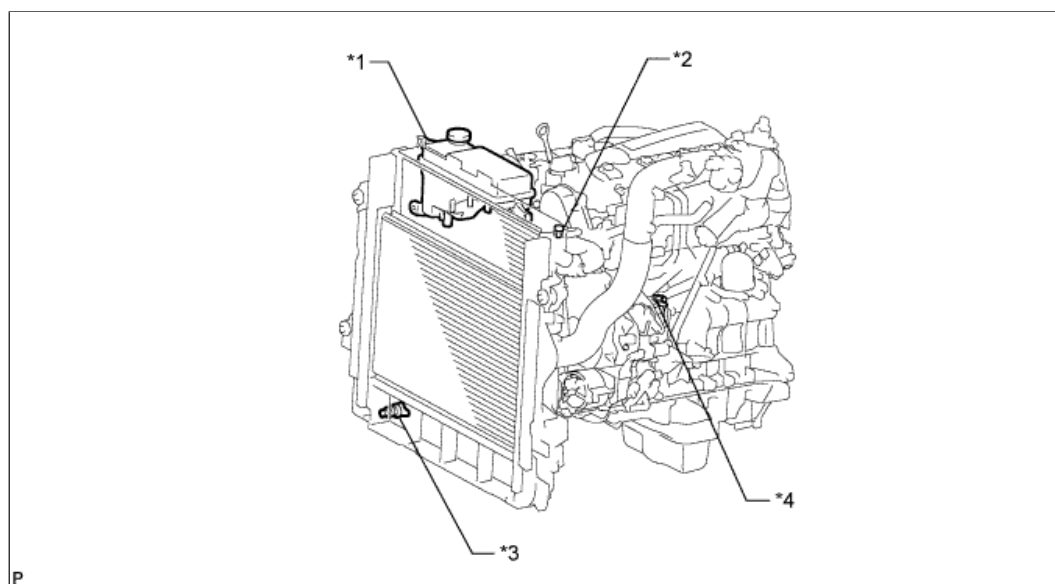

Text in Illustration

*1	Radiator Reservoir	*2	Vent Plug
*3	Radiator Drain Cock Plug	*4	Cylinder Block Drain Cock Plug

5. REMOVE FRONT FENDER APRON SEAL RH

- a. Using a clip remover, remove the 4 clips and front fender apron seal RH.

6. REMOVE FRONT NO. 1 FENDER APRON TO FRAME SEAL RH

- a. Using a clip remover, remove the 5 clips and front No. 1 fender apron to frame seal RH.

7. REMOVE UPPER RADIATOR SUPPORT SEAL

- a. Remove the 13 clips and upper radiator support seal.

8. REMOVE FRONT HEATER BRACKET (for Cold Area Specification Vehicles)

- a. Remove the 2 bolts and front heater bracket.

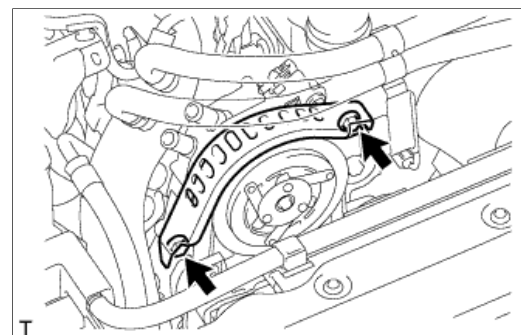

9. REMOVE FAN AND GENERATOR V BELT

- a. Using the pulley set bolt of the tensioner, rotate the tensioner pulley clockwise to loosen the belt tension. Then remove the V belt.

10. REMOVE NO. 1 AIR CLEANER HOSE

- a. Loosen the 2 hose clamps and remove the No. 1 air cleaner hose.

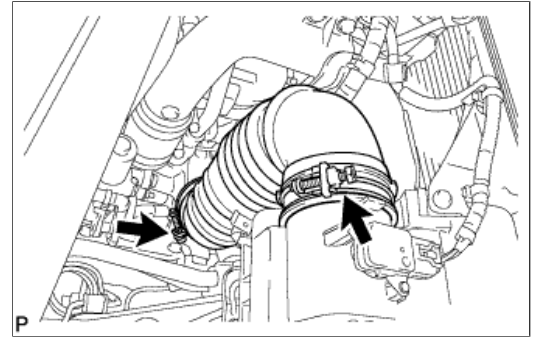
**11. REMOVE AIR CLEANER CAP SUB-ASSEMBLY**

- a. except Cold Area Specification Vehicles:
Detach the 2 clamps and disconnect the mass air flow meter connector.

Text in Illustration

*A	except Cold Area Specification Vehicles
*B	for Cold Area Specification Vehicles

- b. for Cold Area Specification Vehicles:
Detach the 3 clamps and disconnect the mass air flow meter connector.
- c. Detach the 4 clamps and remove the air cleaner cap.

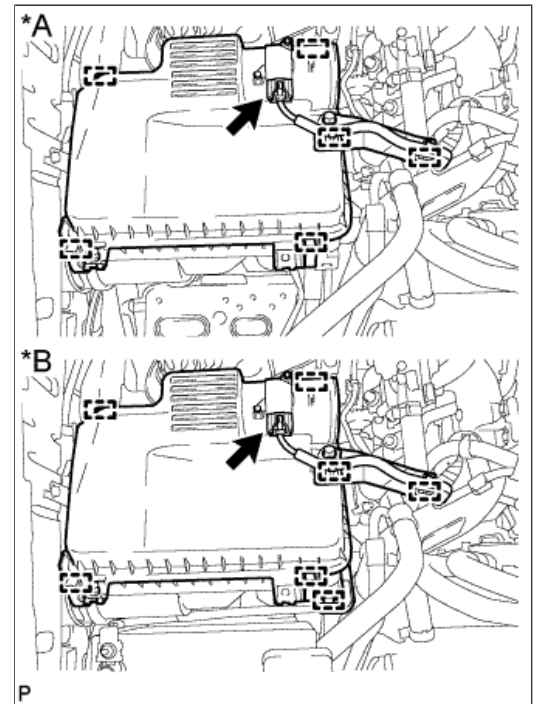
**12. REMOVE AIR CLEANER FILTER ELEMENT SUB-ASSEMBLY****13. REMOVE AIR CLEANER CASE SUB-ASSEMBLY**

- a. Remove the 3 bolts and air cleaner case.

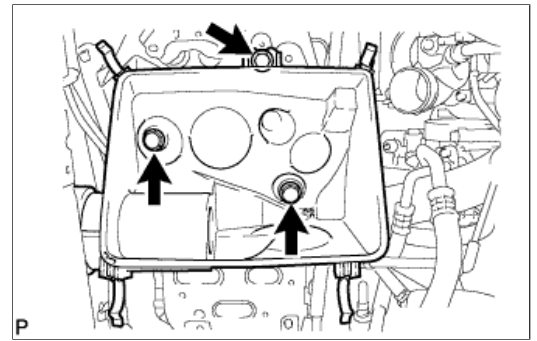

14. REMOVE NO. 1 AIR HOSE

- a. Loosen the 2 clamps.
- b. Remove the No. 1 air hose from the inlet pipe and intercooler.

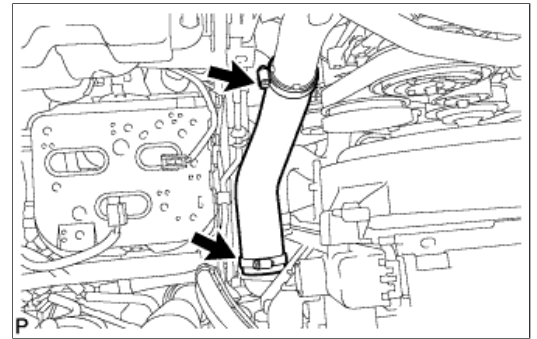

15. REMOVE COMPRESSOR OUTLET ELBOW

- a. Detach the 3 wire harness clamps.
- b. Remove the bolt and wire harness bracket.

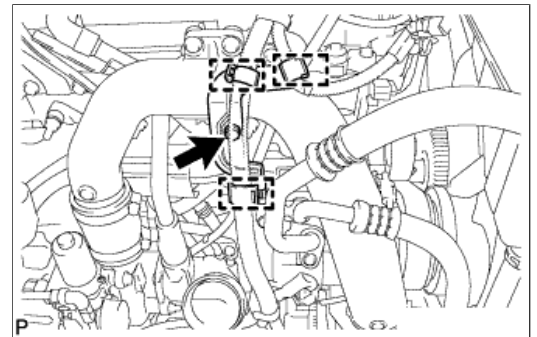

- c. Loosen the hose clamp and remove the 2 bolts and compressor outlet elbow.

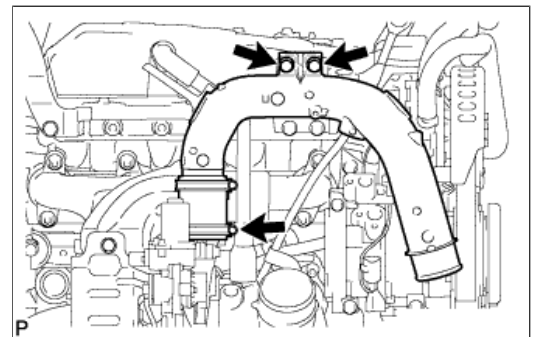

16. REMOVE VISCOUS WITH MAGNET CLUTCH HEATER ASSEMBLY (for Cold Area Specification Vehicles)

- a. Disconnect the viscous heater connector.

- b. Disconnect the water by-pass hose and water hose.

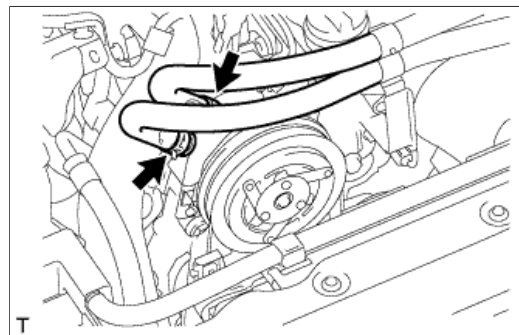

- c. Remove the 2 bolts and viscous heater with magnet clutch.

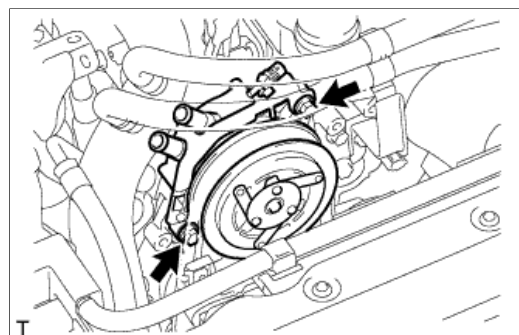

17. REMOVE VISCOUS HEATER NO. 1 BRACKET SUB-ASSEMBLY (for Cold Area Specification Vehicles)

- a. Remove the 4 bolts and No. 1 viscous heater bracket.

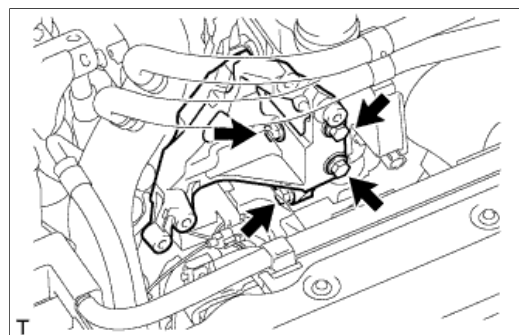

18. DISCONNECT COOLER COMPRESSOR ASSEMBLY (w/ Air Conditioning System)

- a. Disconnect the compressor connector.
- b. Remove the 4 bolts and disconnect the cooler compressor.

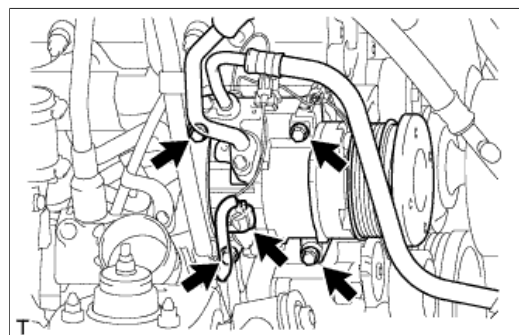

19. REMOVE GENERATOR BRACKET

- a. Remove the bolt and generator bracket.

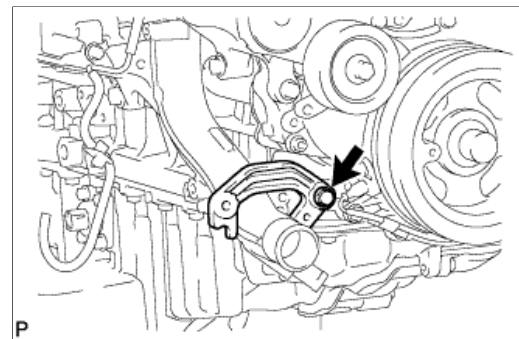

20. REMOVE GENERATOR ASSEMBLY

- a. Disconnect the generator connector.
- b. Remove the terminal cap.
- c. Remove the nut and disconnect the generator wire.
- d. Remove the 2 bolts and generator.

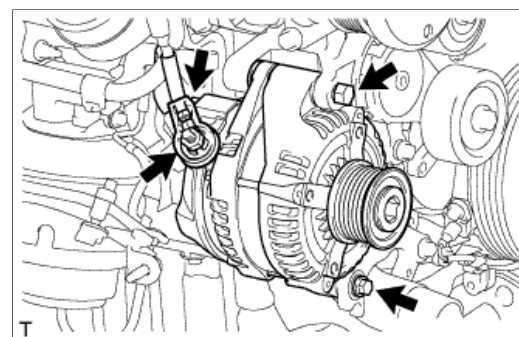

21. REMOVE NO. 1 COMPRESSOR MOUNTING BRACKET

- a. Remove the 5 bolts and No. 1 compressor mounting bracket.

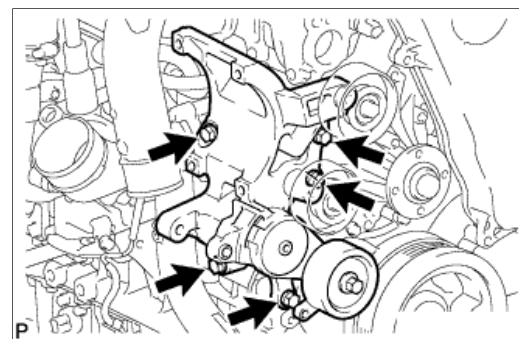

22. REMOVE VENTILATION PIPE

- a. Remove the bolt and disconnect the 2 ventilation hoses and ventilation pipe.

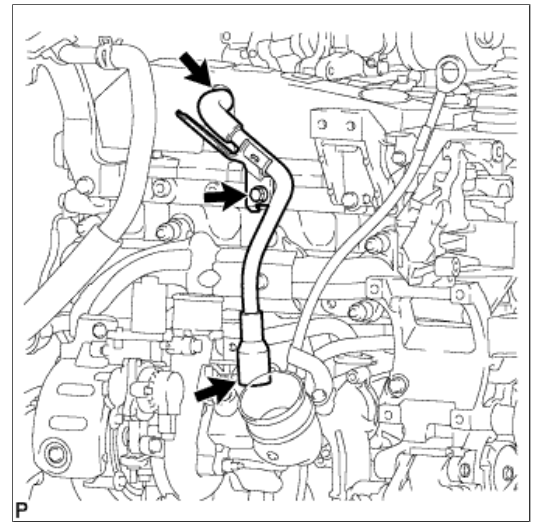

23. REMOVE ENGINE OIL LEVEL DIPSTICK GUIDE

- a. Remove the engine oil level dipstick.
- b. Remove the 2 bolts and engine oil level dipstick guide.
- c. Remove the O-ring from the engine oil level dipstick guide.

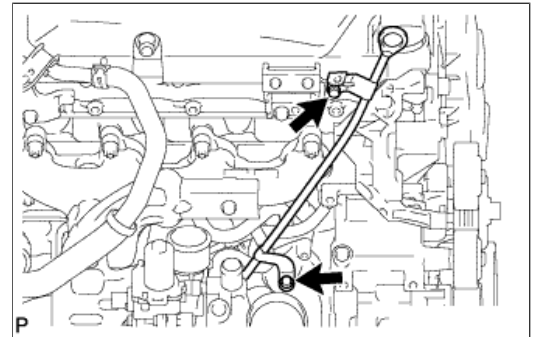

24. DISCONNECT NO. 2 RADIATOR HOSE

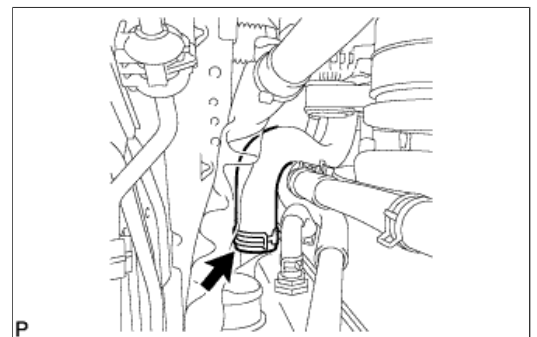

25. DISCONNECT NO. 2 WATER BY-PASS HOSE

- a. Disconnect the No. 2 water by-pass hose from the water inlet.

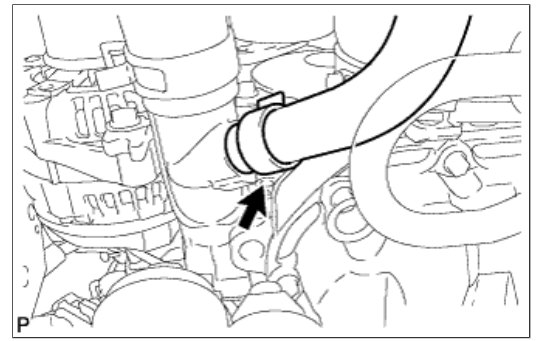

26. REMOVE WATER INLET

- a. for Automatic Transmission:
Remove the 2 bolts from the oil cooler tube clamp and bracket.

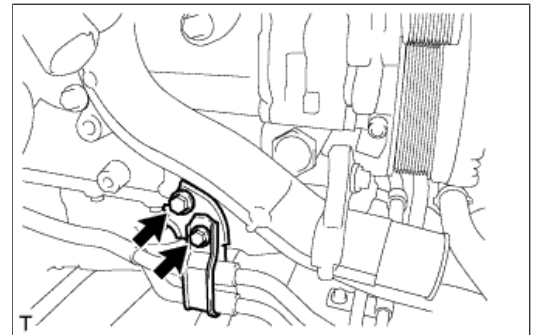

- b. Remove the 3 bolts and inlet.



27. REMOVE THERMOSTAT

- a. Remove the thermostat.
- b. Remove the gasket from the thermostat.

