

i-AB - Earth Leakage Relay

Overview:

M-Tronix is your source for highly innovative electronic control, protection, and monitoring systems for mining and general industry. M-Tronix is your exclusive distributor of the **Bramco** product range.

Application:

Leaders in Innovative Protection Systems, the Bramco M-Tronix i-AB is compliant to latest statutory and industry standards. The M-Tronix Earth Leakage Relay i-AB, has been designed to detect Earth Fault Currents flowing in a power system.

Features:

- Machine or power operated
- Latching/non-latching mode switch
- Fail safe or non-fail safe operation
- Adjustable time discrimination
- Adjustable trip current point
- LED indication of power on
- LED warning when the leakage current rises above the trip current set point
- LED indication when latched
- Current loop or voltage output 20mA or 2-10V
- Use with range of m-Tronix Earth Leakage toroids.

Ordering Information:

- A00019A:** 500mA-500mS, 110vAC
- A01171A:** 500mA-500mS, 240vAC
- A01045C:** 500mA-500mS, 24-48vAC/DC
- A00270B:** 500mA-500mS, 110VAC - 4-20mA Output
- A00571B:** 100mA-100mS 110V
- A00572B:** 100mA-100mS 24v
- A00752A:** 30mA-100mS 110v (Non-adjustable Trip)

Specifications:

Supply:

- 110VAC 50/60Hz Standard
- 240VAC 50/60Hz Optional
- 24VAC or DC 50/60Hz Optional
- 48VDC 50/60Hz Optional

Voltage Tolerances: -30% to +20%

Material: High impact Poly Carbonate

Trip Delay:

- Adjustable from 30 to 500mS
- Optional 1secs, 2secs and 5secs

Trip Current:

- Adjustable from 50 to 500mA
- Optional 1A, 2A and 5Amp

Enclosure

Dimensions: 55mmW x 75mmH x 110mmD

Material:

- High impact resistant polycarbonate construction
- IP20 Rating

Mounting: DIN rail

Terminals: Cage screw terminals

Weight: 216gms

Compliance:

N.S.W Mines MDA EXib 11317
 QLD Mines QMD 947346X
 AS 2081:2002.3-1988 Compliant
 (both approvals for 500mA/500mSec only)

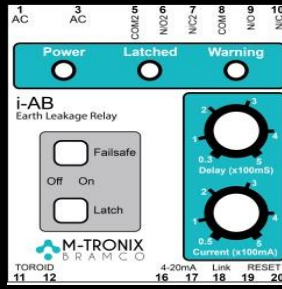

i-AB

Earth Leakage Relay

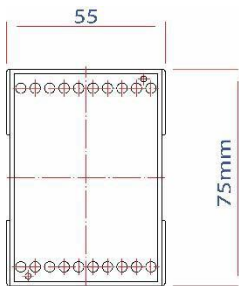
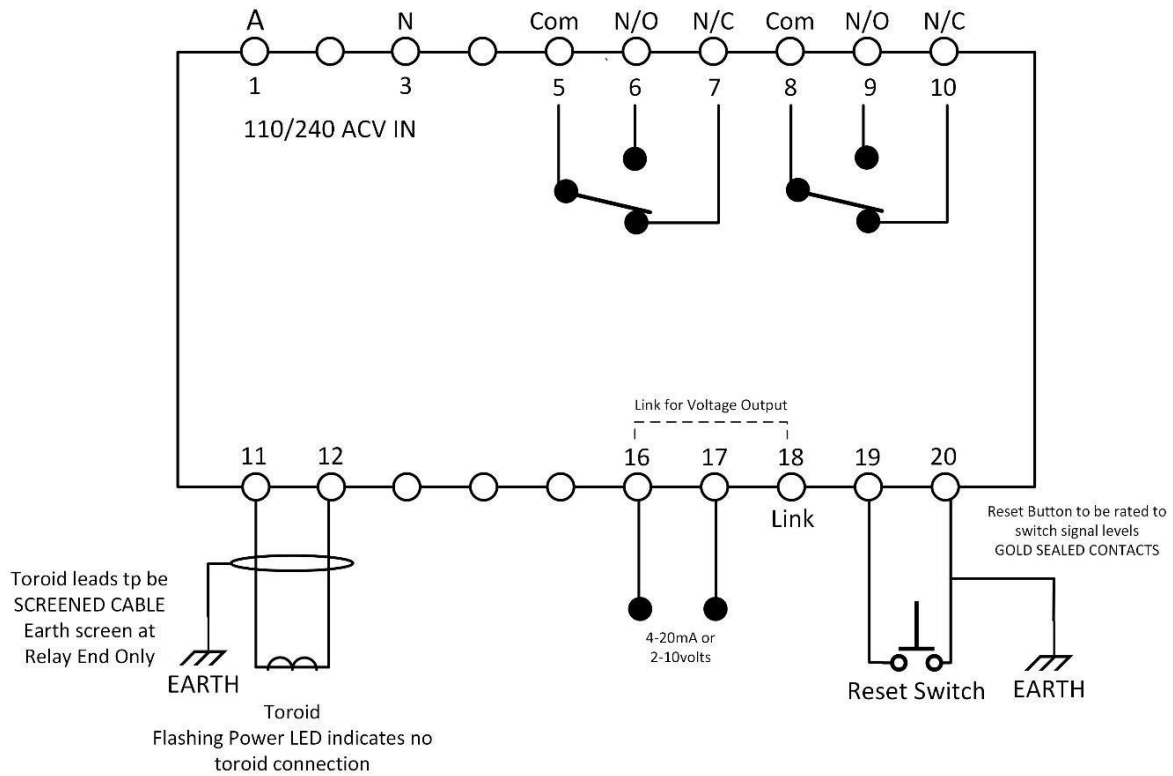

Enclosure
Dimensions: 55mmW x 75mmH x 110mmD

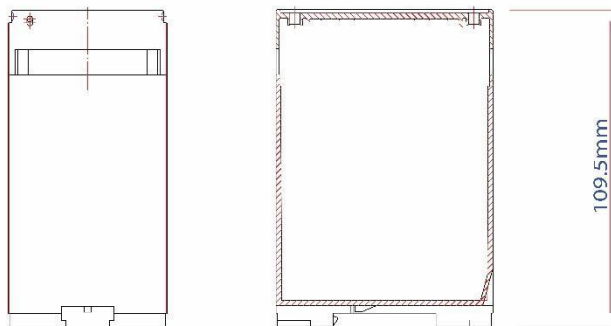

M-TRONIX Contacts
Telephone +61 435 939 513
Email: info@m-tronix.com.au
www.m-tronix.com.au

Compliance:
AS/NZS 2081:2011
The i-AB comes with a 2-year warranty.