

iC Earth Continuity Relay

Overview:

M-Tronix is your source for highly innovative electronic control, protection, and monitoring systems for mining and general industry. M-Tronix is your exclusive distributor of the Bramco product range.

Application:

Leaders in Innovative Protection Systems, the iC is compliant to relevant statutory and industry standards.

The Earth Continuity Relay iC, has been designed to monitor the continuity of the Earth Circuit in a supply cable by grounding the pilot core via a diode, polarised positive to earth.

Features:

- Fail-safe operation
- Detection of pilot wire shorted to earth
- LED indication of power on
- LED warning when an earth continuity fault occurs
- Higher (non-approved) maximum resistance range available to special order
- Easy modification to suit Pilot Control operation available
- Special 100mSec reduced trip time model available

Ordering Information:

- A00020A:** iC Relay 110vAC
A00936A: iC Relay 240vAC
A00462A: iC Relay 24-48vAC/DC
A00474A: iC Reduced trip time 100mSec 110v/240vAC
A00478A: iC Reduced trip time 100mSec 24vAC/DC

Specifications:

Supply:

- 110vAC 50/60Hz standard
- 240vAC 50/60Hz optional
- 24vAC or DC 50/60Hz optional
- 48vDC 50/60Hz optional
- 40/50Hz optional

Power: 3VA +/-20%

Operating Temp: 0 – 60° C

Pilot to Earth Resistance: 0 – 45 Ohms

Fail Safe: Relay contacts energised whilst diode is healthy and earth resistance levels less than 450hms.

Pilot Wire: Diode termination to earth at remote end of cable.

Relay Contacts:

2 x Changeover contacts
 5A - 240V AC

Enclosure:

Dimensions: 75mmW x 55mmH x 110mmD

Material:

- High impact resistant polycarbonate construction
- IP20 Rating

Mounting: DIN rail

Terminals: Cage screw terminals

Weight: 216gms

This product is designed and manufactured in accordance with ISO9001:2000 requirements.

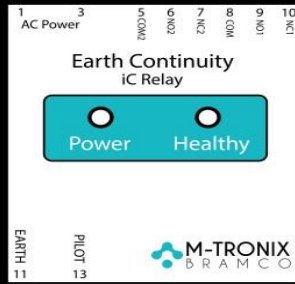

Wiring Diagram

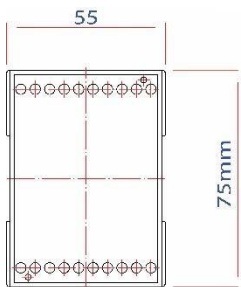
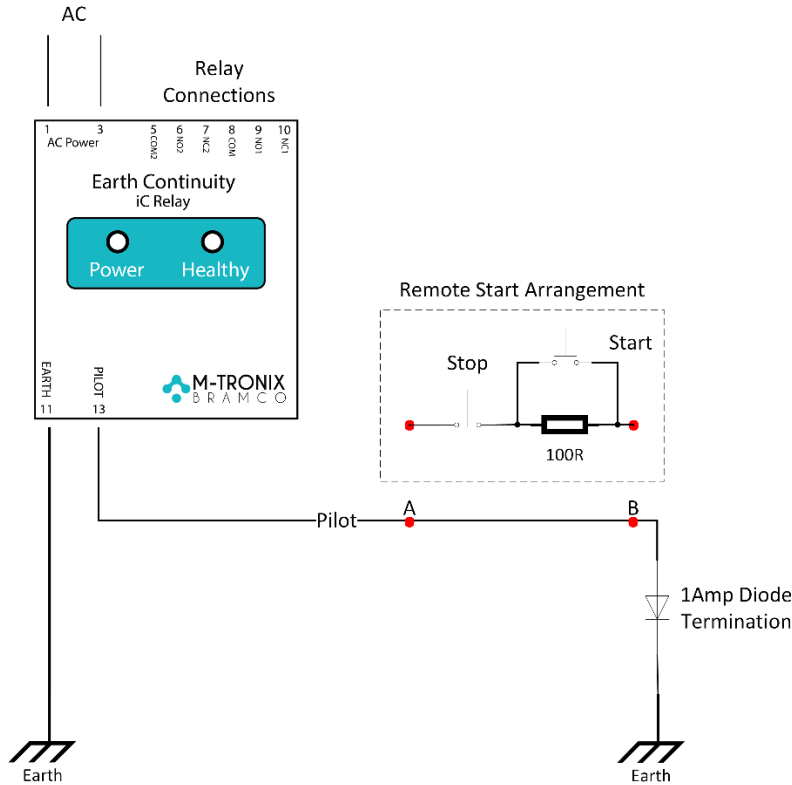

Enclosure
Dimensions: 55mmW x 75mmH x 110mmD

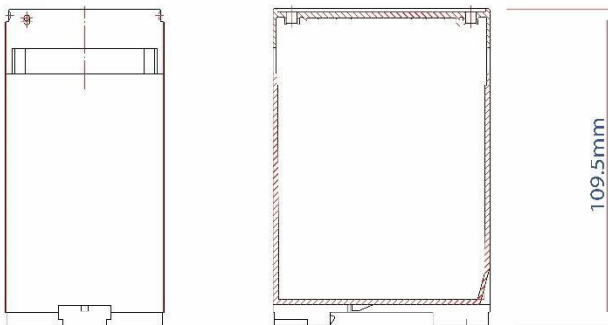

M-TRONIX Contacts
Telephone +61 435 939 513
Email: info@m-tronix.com.au
www.m-tronix.com.au

Compliance:
AS/NZS 2081:2011
The iC comes with a 2-year warranty.