

TRICKY TURNABOUTS

Here we look at some more turnabouts. Some are probably too tricky to be risked in a serious game. But i bet that Macka uzed some of em.

TURNABOUT 6A

This turnabout is actually one that would be ok out near mid-cushion, but it is even friendlyr near the side-cushion, kozuken uze TURNABOUT 1 if u stuff-up.

U havta hit the red very thin, and u havta take the qball throo az far az u dare. A thin half-ball with running-side duz the trick. The yellow hazta go past the red, az shown. The uzual stuff-up iz to hav the yellow kiss the red. This will stop the yellow and bump the red out, giving a cover (& u will need to uze the side-cushion next shot).

But, played well, u will leev an eazy direct cannon (shown), albeit thin.

TURNABOUT 6B

Here iz the same pozy, but with the qball closer to the cushion.

On this angle it iz eazy to take the yellow past the red without risk of a kiss. The down-side iz that (on this angle) we cant get the qball east of the red. So, we know that we havta bump the yellow well ahead. So, we hit the yellow half-ball, with check-side, to take it further.

TURNABOUT 6C

Here the qball iz a little further from the cushion. The pozy looks ok, but it iz deceptiv. It iz almost impossible to play this sort of turnabout here. Koz it iz close to ok, u will be tempted to uze soft-screw, or a little swerve. But, uken try anything u like and u will fail. U will get the red too thick, or the yellow will kiss the red, but uzually u will get both. It's simple geometry. At close range, a few mm'z add up to a lot of degreez.

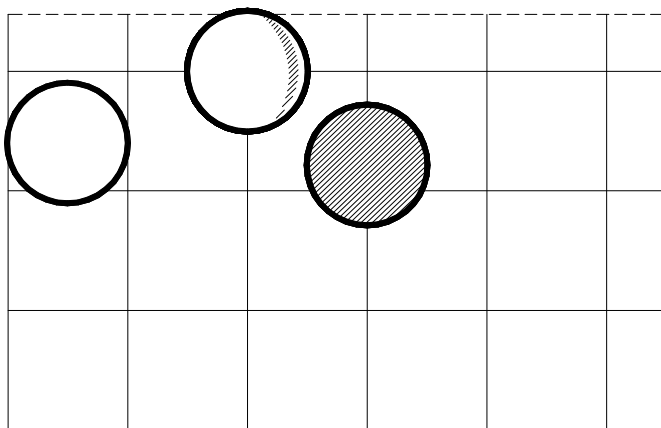
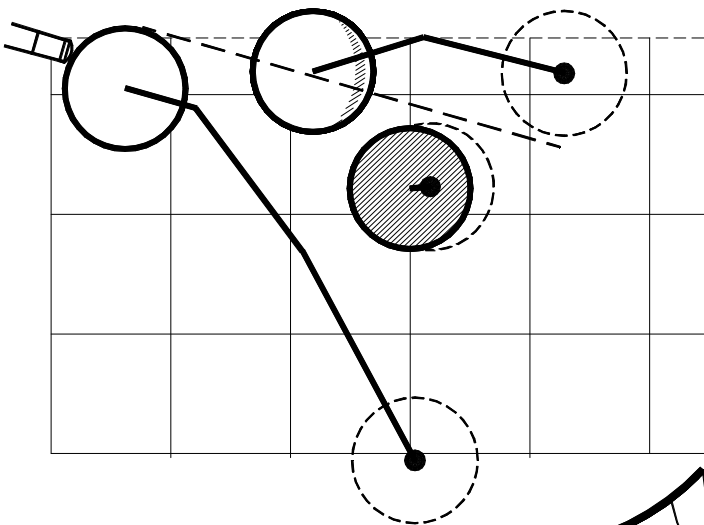
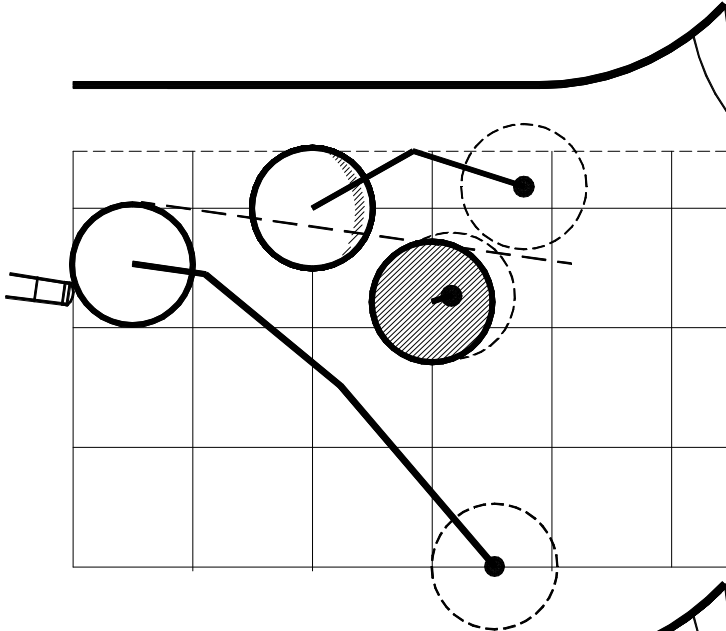

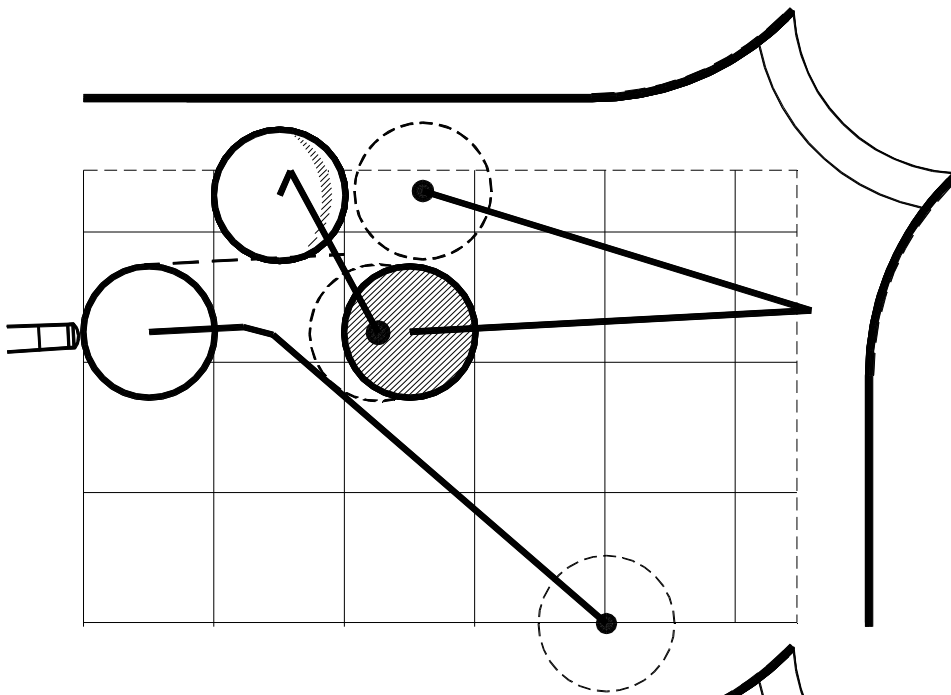

TURNABOUT 7A

This one needz the side-cushion -- it's not az hard az it looks. Everything hazta be spot-on -- the contacts on yellow and red, and the pace of both yellow and red. The red hazta hit just inside the jaw. At this range there iz a large margin-for-error, but be careful all the same. The distance from the side-cushion iz perfikt, u don't want to be further (the margin-for-error iz poorer) and u don't want to be closer. I could show lots of variationz needing a little check-side or running-side (to giv the red a good line), but u know all that stuff.

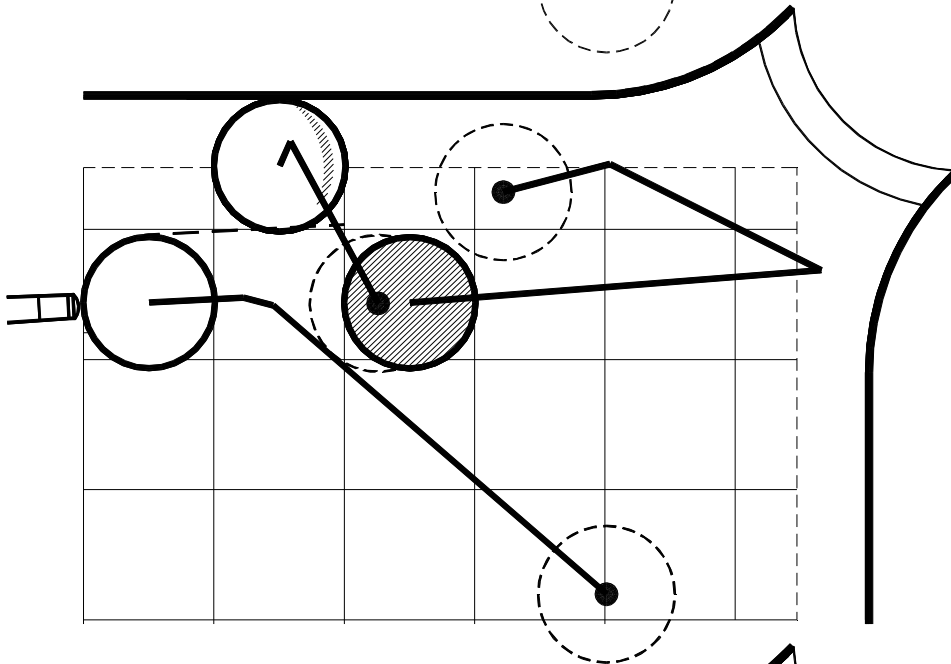

TURNABOUT 7B

The same pozzly az 7A, but the yellow iz on the cushion. We hit the yellow thinner. Even so, the red gets a lot of the jaw, but it still goze to good pozzly (off the top-cushion). Some check-side may help to giv the red a good line. And we havta hit hardish, koz the double-kiss takes pace off the yellow.

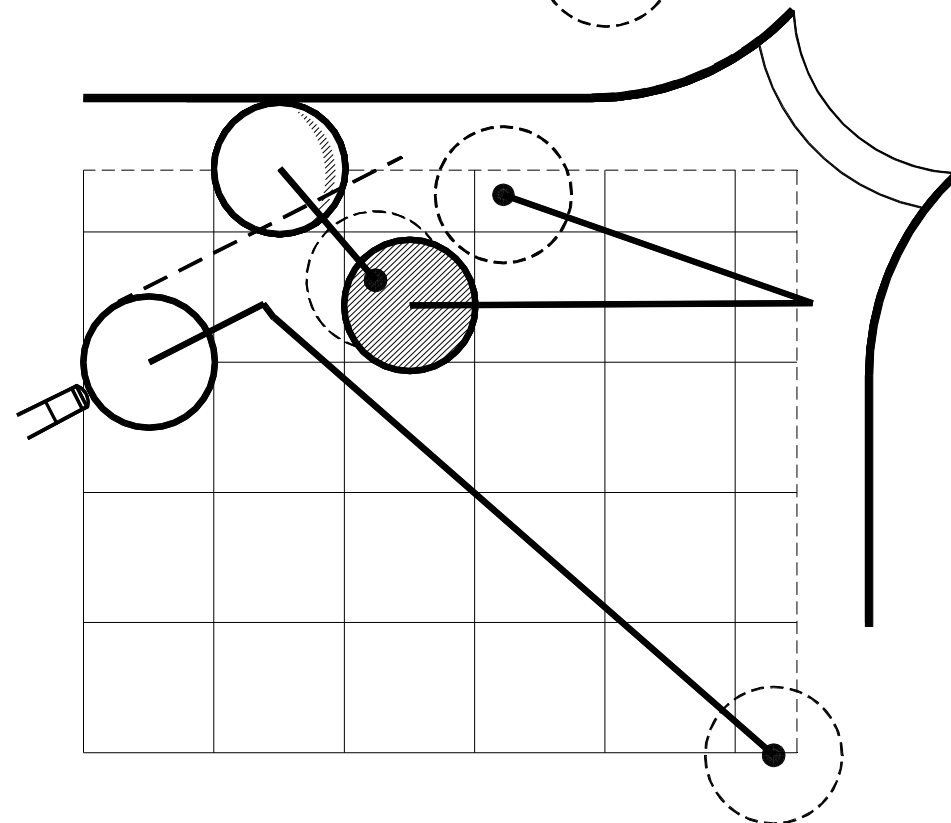

TURNABOUT 7C

The same pozzly az 7B, but the qbball iz well out. If we try to play thinnish on yellow, the double-kiss will giv the red a good line. But this iz a trap -- if u try to hit the yellow thin, u will hit the red first. Anyhow, luckyly, here we havta hit the yellow thickish, and hardish, koz the double-kiss robz much of the yellow'z pace.

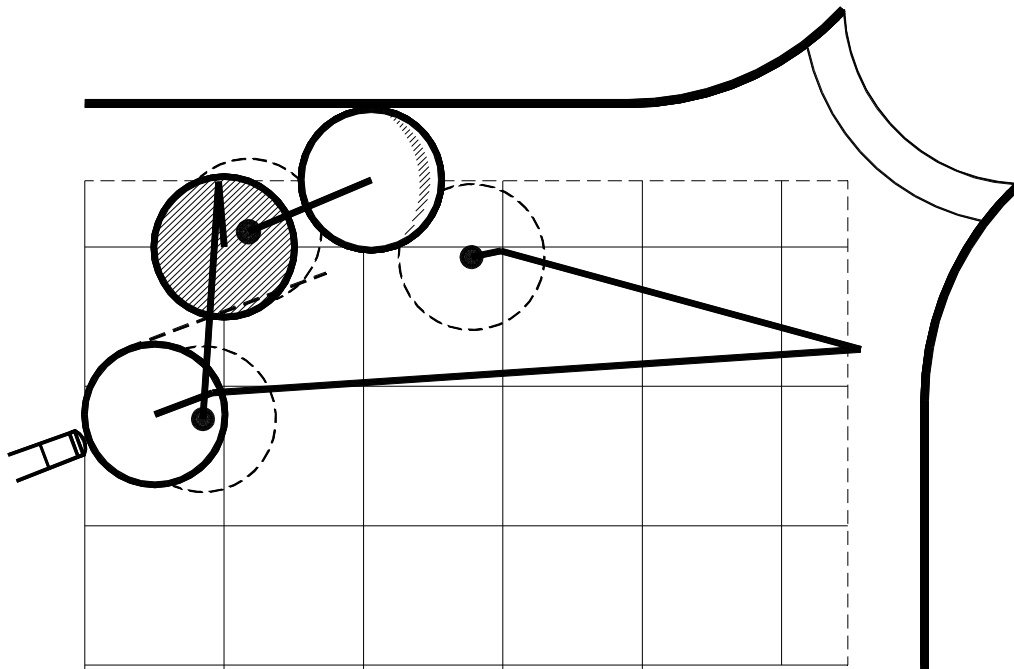

TURNABOUT 11A

Here we double the red off the cushion into nice pozy.

We uze feel to judge the correct contact on red, and the correct contact on the jaw.

For accuracy, the shot should be played by reeching over the western side-cushion.

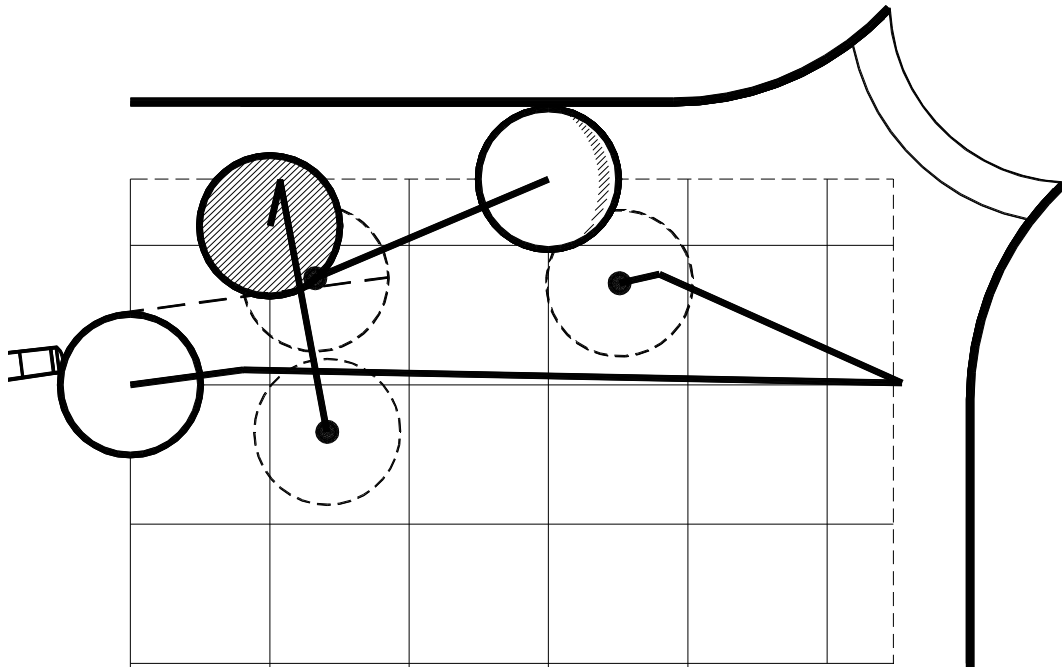

TURNABOUT 11B

Here's a variation of 11 A.

This time we havta uze lots of check-side.

The uzual stuff-up iz to hit the red too thick, and to uze too little side-spin.

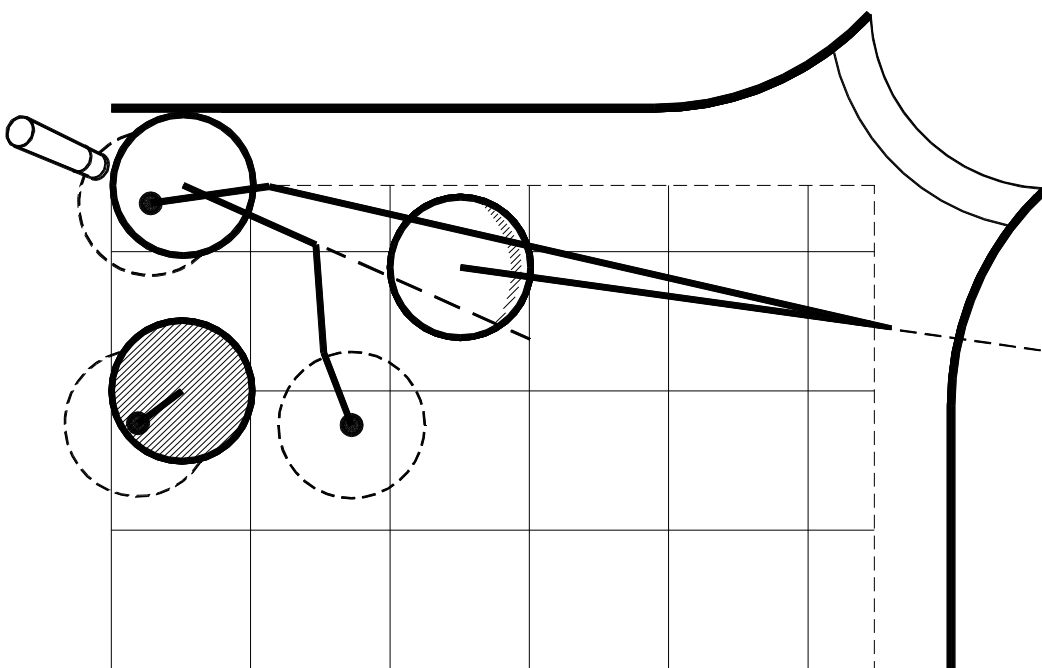

TURNABOUT 12

The yellow needz to be hit just left of the J-Spot.

If in trouble, uken try to set up this sort of pozy. It needz a large gap between red&yellow.

U will hav to hit down, due partly to the cushion, az shown.

TURNABOUT 13A

Ok, here's how Macka probably did it. Let's start with run-along AA pozy.

Now, it's usually easier to turn-about if we can get the balls out further.

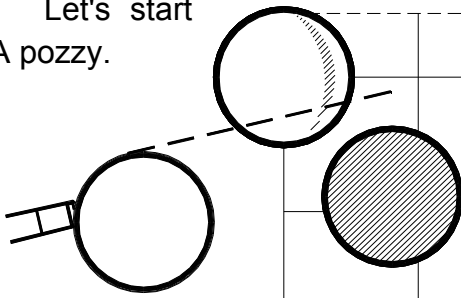

So, we play a crisp $\frac{1}{4}$ ball on yellow, with check-side, to leave 13B. The $\frac{1}{4}$ ball gives a larger Deflexion Angle, & the check-side keeps the ball from leaking south.

TURNABOUT 13B

It would be nice to have perfect pozy, like 6A, where you could just roll the balls every shot, maybe using some side. But, the reality is that most of the time Macka would get something like 13B.

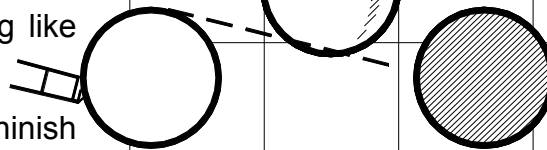

Here Macka has to play a thin screw, to leave 13C. The main thing is to graze red as thinly as you dare. Right-hand-side can make this easier to judge. And, the thin contact keeps yellow from leaking too far east.

Practically these thin-screws & you acquire feel. Feel is better than judgement.

TURNABOUT 13C

Macka now has 3 options.

- (1) The thick run-thru.
- (2) The thin cannon.
- (3) A cushion-cannon.

The main problem with 1 & 2 is that a right-hander has to reach out & back, or use her left hand, or use the rest. So, compare this sequence to others. Having the thin-screw up your sleeve makes it the easiest by far. It's like having your own key to Macka's billiard room.

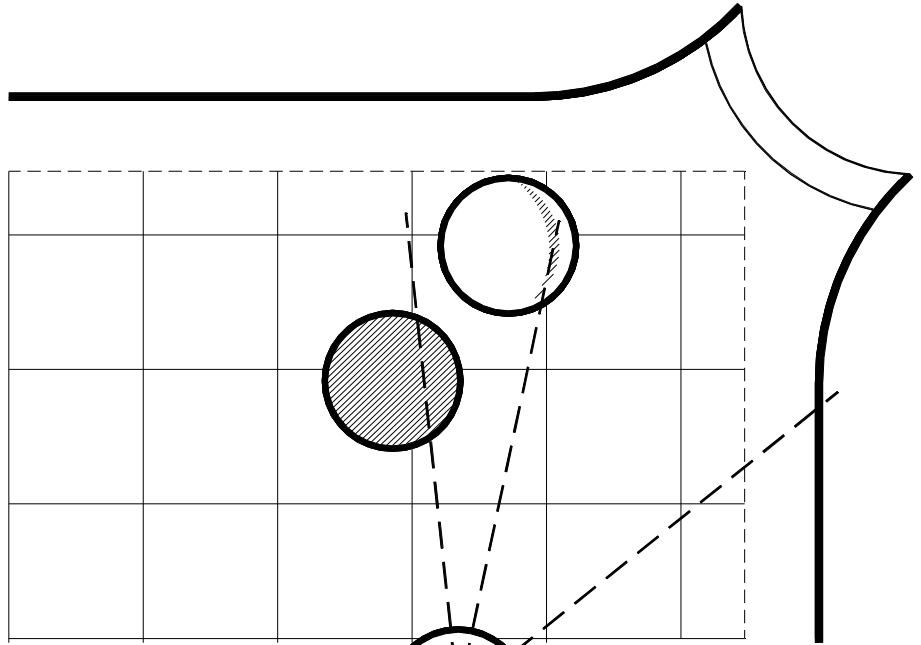
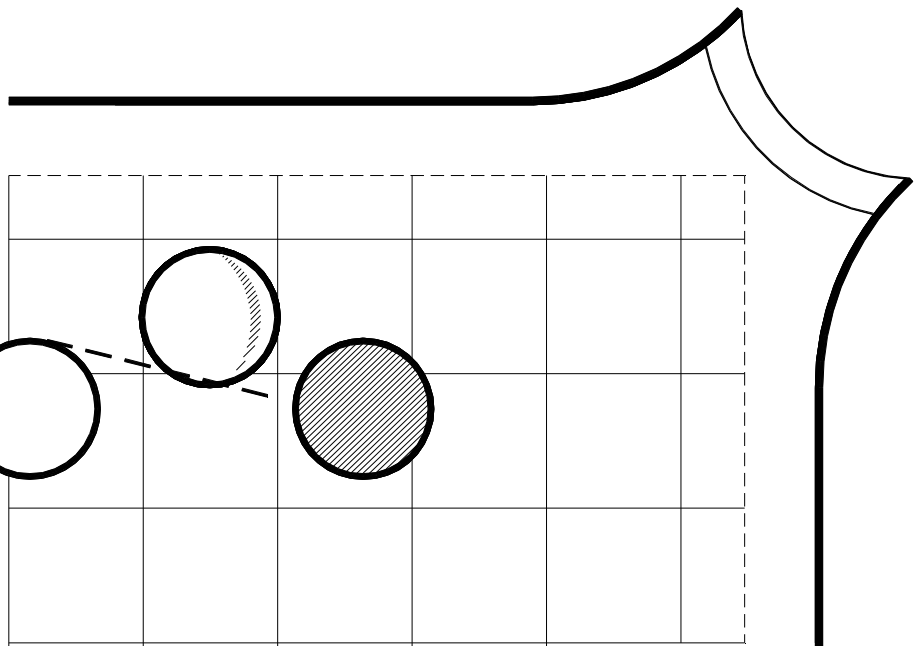
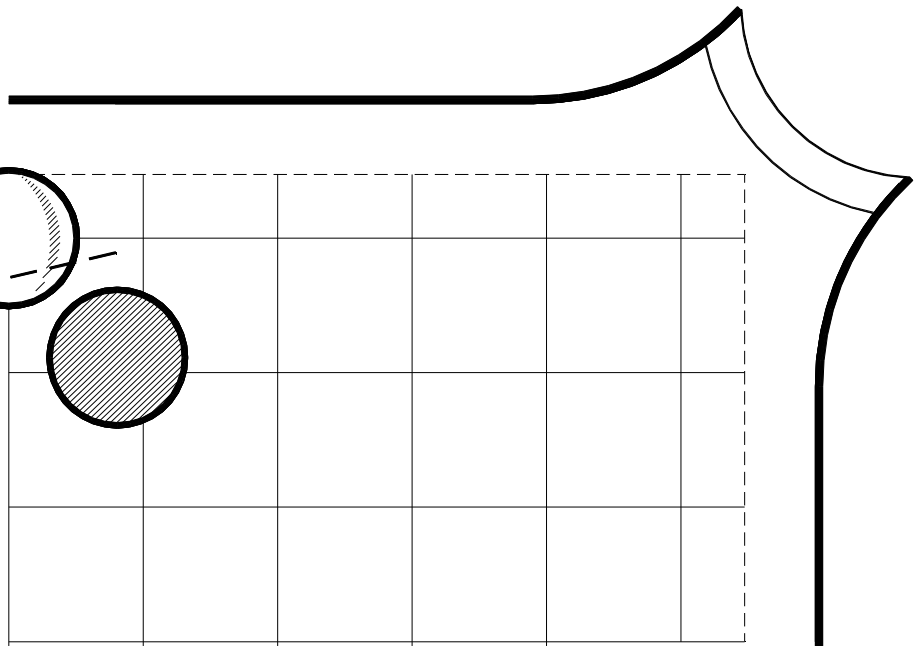

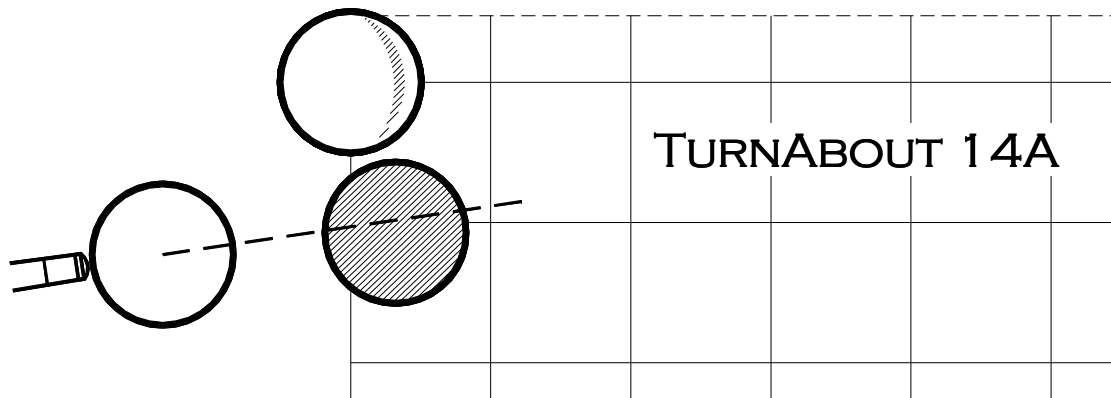

Here i reckon Macka would bump the red well ahead, to leev 14B. Don't bump yellow too close to the cushion.

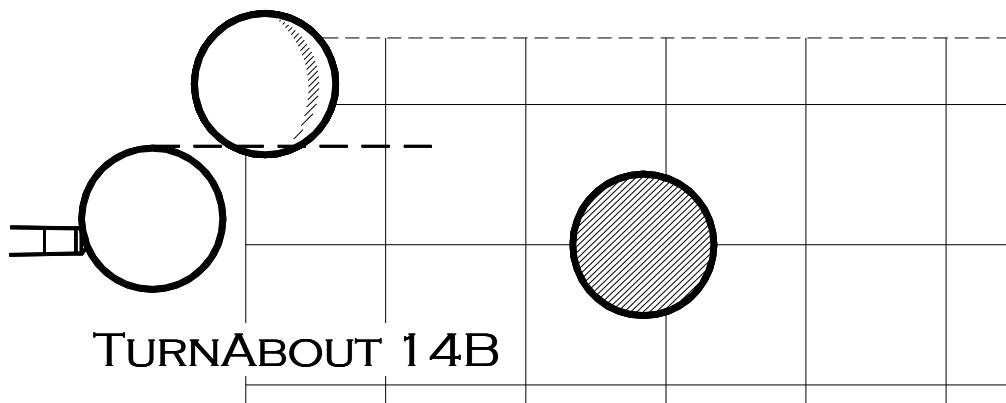

Here iz that thin-screw again. Graze red az thinnly az u dare, leaving 14C. Its amazing how thin u havta hit yellow to stop it from going too far east & hitting the red.

TURNABOUT 14C

This will uzually be a red-first cannon. Anyhow, this iz another very eezy sequence. The thin-screw iz the key. It ken make a mug feel like Macka. But, right-handerz should praktis all of this near the left top-pocket, mirror-image, koz that's where it will be of most use. Praktis the mirror-image of the thin-screw, the key shot.

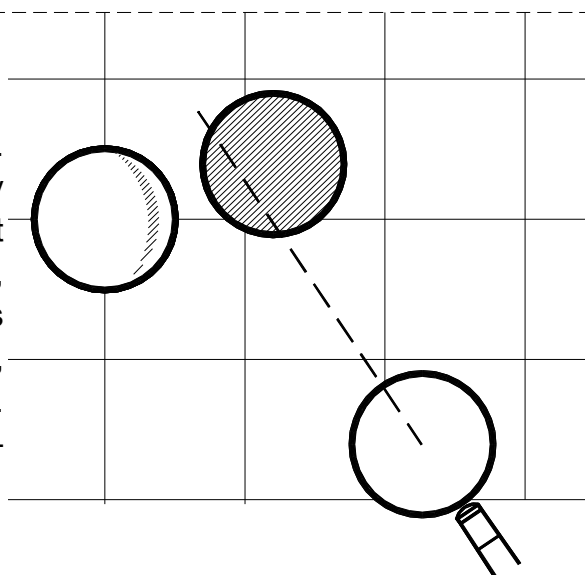

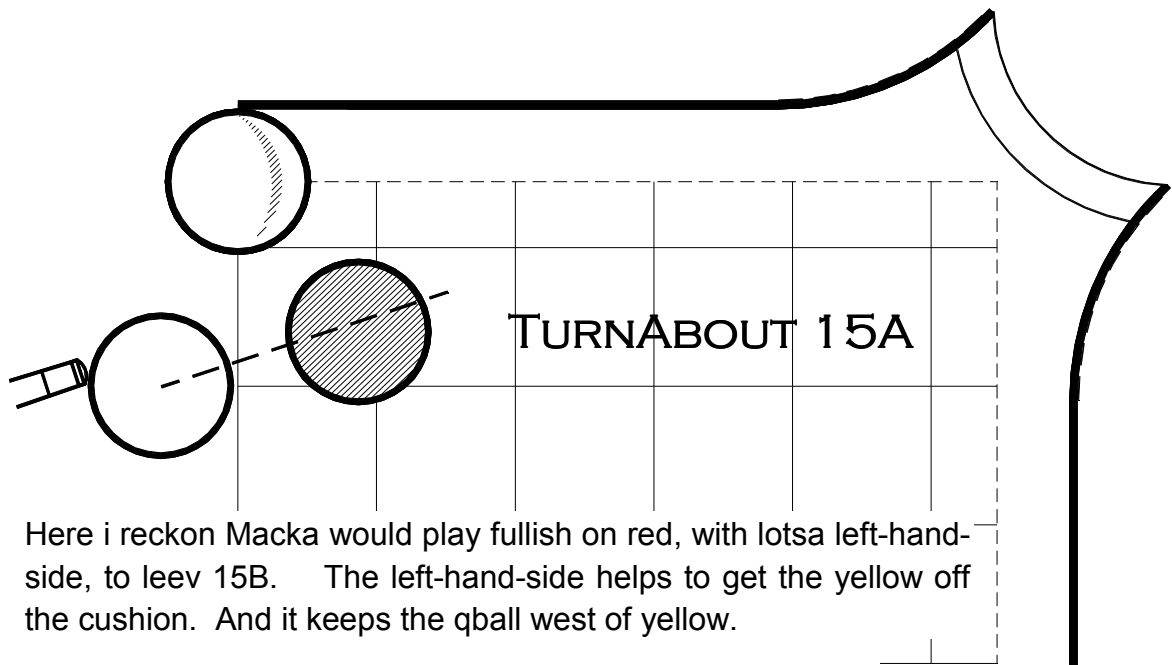

TURNABOUT 15A

Here i reckon Macka would play fullish on red, with lotsa left-hand-side, to leev 15B. The left-hand-side helps to get the yellow off the cushion. And it keeps the qball west of yellow.

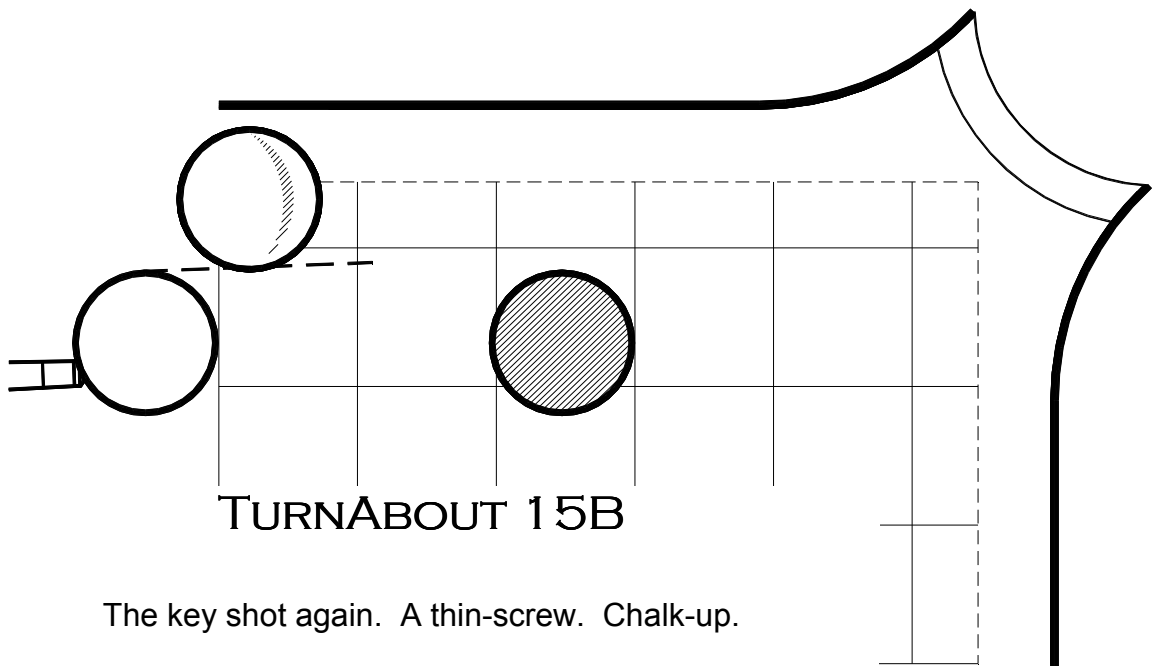

TURNABOUT 15B

The key shot again. A thin-screw. Chalk-up.

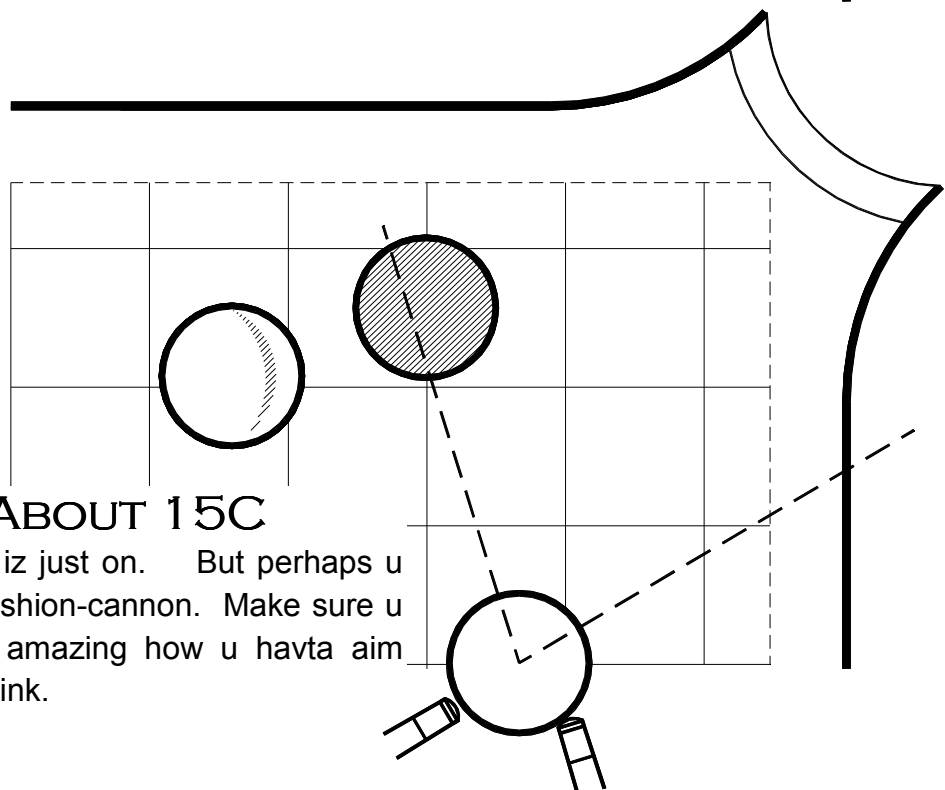

TURNABOUT 15C

Here the run-throo iz just on. But perhaps u would prefer the cushion-cannon. Make sure u praktis theze. Its amazing how u havta aim further left than u think.

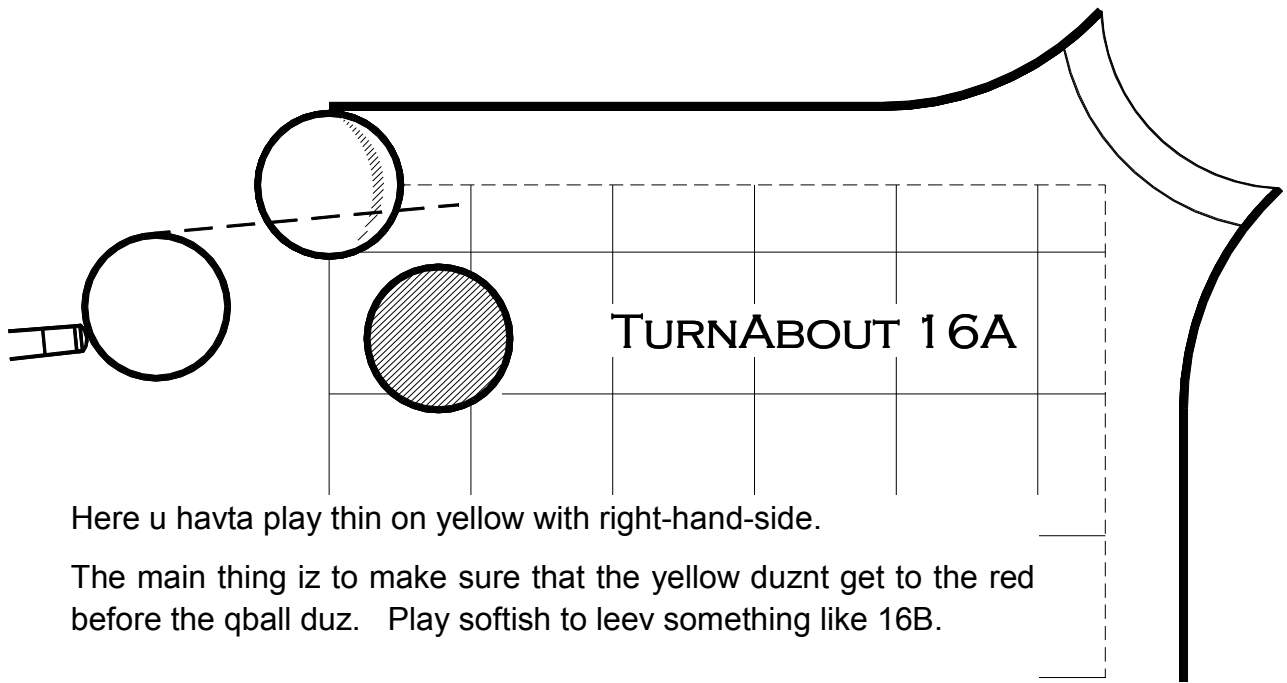

Here u havta play thin on yellow with right-hand-side.

The main thing iz to make sure that the yellow duznt get to the red before the qball duz. Play softish to leev something like 16B.

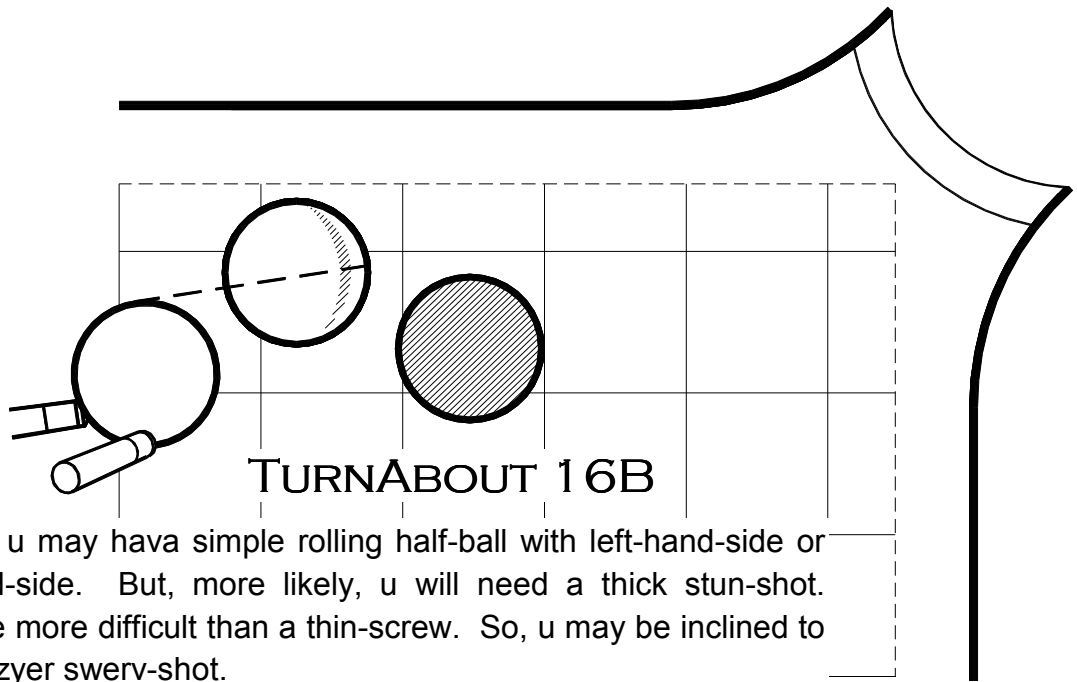

With luck u may hava simple rolling half-ball with left-hand-side or right-hand-side. But, more likely, u will need a thick stun-shot. These are more difficult than a thin-screw. So, u may be inclined to try the eezyer swerv-shot.

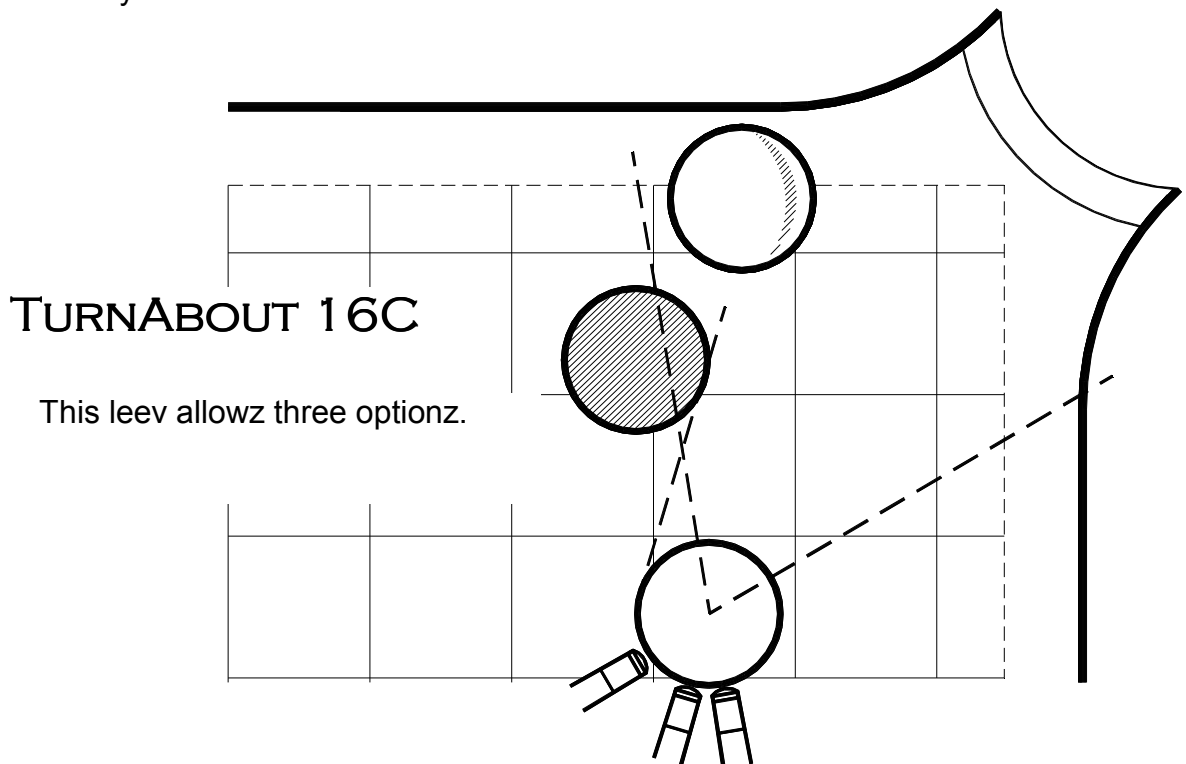

This leev allowz three optionz.

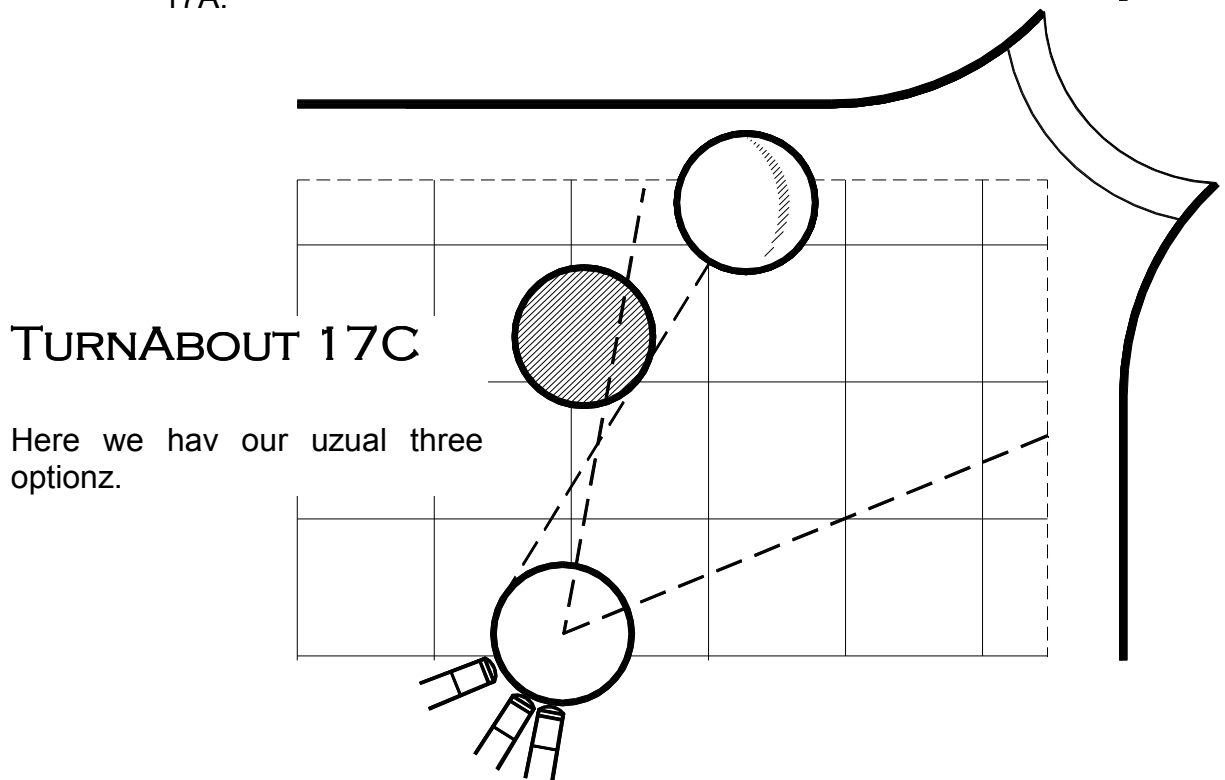
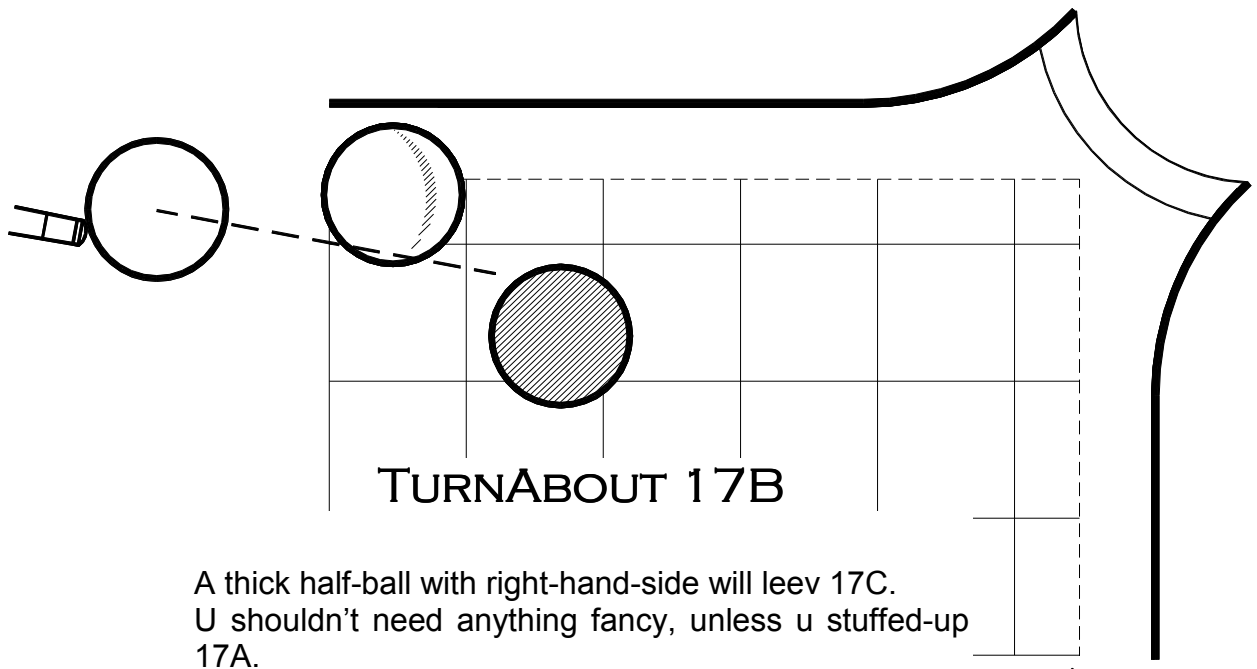
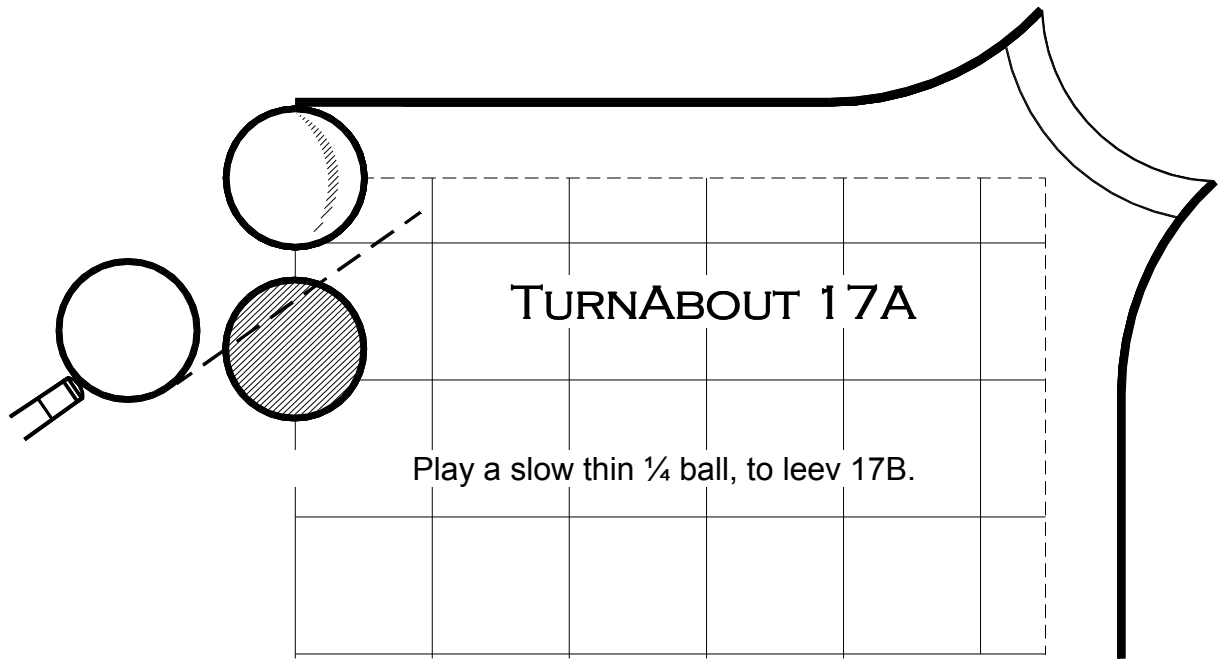

TURNABOUT 18

Here'z another one for the book. Here we hit red first. It's a good backup for when TURNABOUT 13 goze haywire.

The Times, 4 Dec 1919. Lindrum had begun a run of cannons on the top cushion & was playing towards the right side of the table. This is not the most suitable side, as Lindrum is a left-handed player, but just before he reached the pocket he played a little flick cannon, driving the first object ball on to the side cushion & cleverly reversed the position.

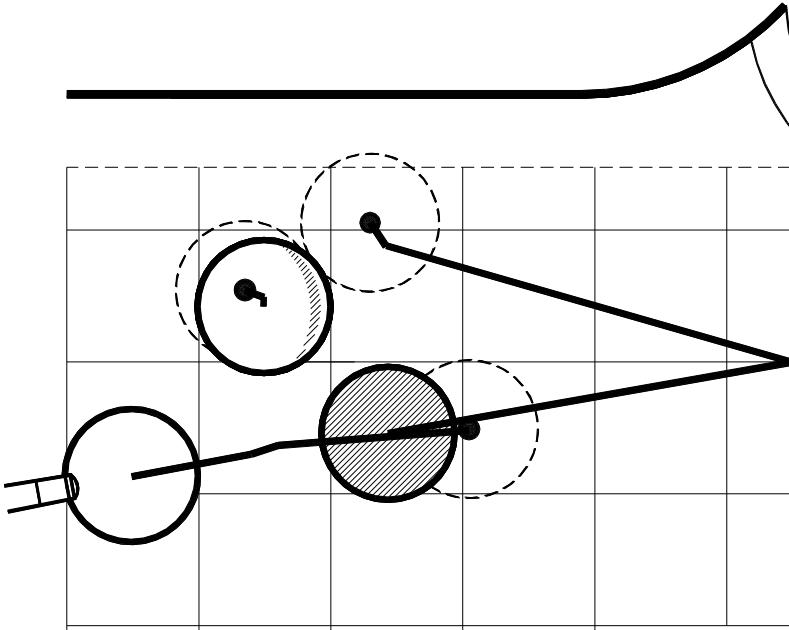

TURNABOUT 19

This iz just another verzion of TurnAbout 8.

U should hav another look at all of the tricky onez, koz they are all useful if u get into trouble.

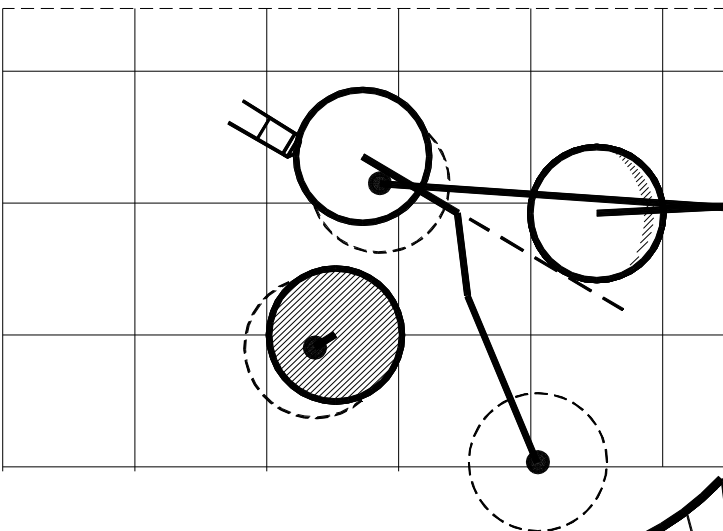

TURNABOUT 20

This sortev pozzey kumz up lots. And i could write a whole chapter on it.

Here uze lotsa right-hand-side to clear the red to the west.

U should praktis varyationz, ie different anglez & gaps etc. The main thing iz to avoid the yellow kissing the red twice. Get a feel for what iz needed to maximize ya chancez of getting good nursery cannon pozzey.

