

TOBEE

Always do your best pump®

A large, blue industrial pump is the central focus of the image. It has a circular grate around its central opening. The pump is mounted on a metal frame. In the background, a factory setting is visible with various pieces of equipment and structural elements. The pump has 'TOBEE PUMP TG14/121' cast into its metal housing.

Series TG, TGH Dredge & Gravel Pumps

Tobee TG Pumps: L

Overview

Tobee Gravel Sand Pump is designed specifically for continuous pumping of extremely aggressive slurries, sands, gravels etc, with a wide channel for handling large particles at consistently high efficiencies results in low cost of ownership. The wet parts are made of Ni-hard and high-Chrome alloys for further increasing component life.

Design and Unique Features

1. The unique segmented clamp ring on larger size units and solid on smaller pumps, facilitates casing rotation to any angle, reducing the need for costly high wearing bends. Minimal maintenance is required.
2. Impeller expulsion vanes reduce gland pressure and intrusion of high concentrations of solids in the gland area. Efficiency is maintained by minimising suction side recirculation.
3. Specially designed and shaped impeller vanes allow the handling of extraordinarily large particles. The unique casing design and sealing vanes prevent abrasive solids intrusion at the sealing faces.
4. The large, robust casing has been designed to reduce internal velocities resulting in minimum efficiency loss and improved casing wear life. The casing is made up of three components to reduce maintenance time and costs associated with a one-piece design. (Except the TG 6/4 D which has two components)
5. Tobee heavy-duty grease lubricated taper roller bearing assemblies are fitted as standard. A rigid large diameter shaft with reduced overhang minimises deflection and vibration under all conditions ensuring trouble free operation. Unusually high service factors enable the assembly to carry all radial and axial thrusts.
6. A unique "-10" (dash 10) end cover assembly comprising of V-seals, double piston rings and an external flinger with grease lubricated labyrinths are standard with all Tobee pumps.



Sectional Arrangement

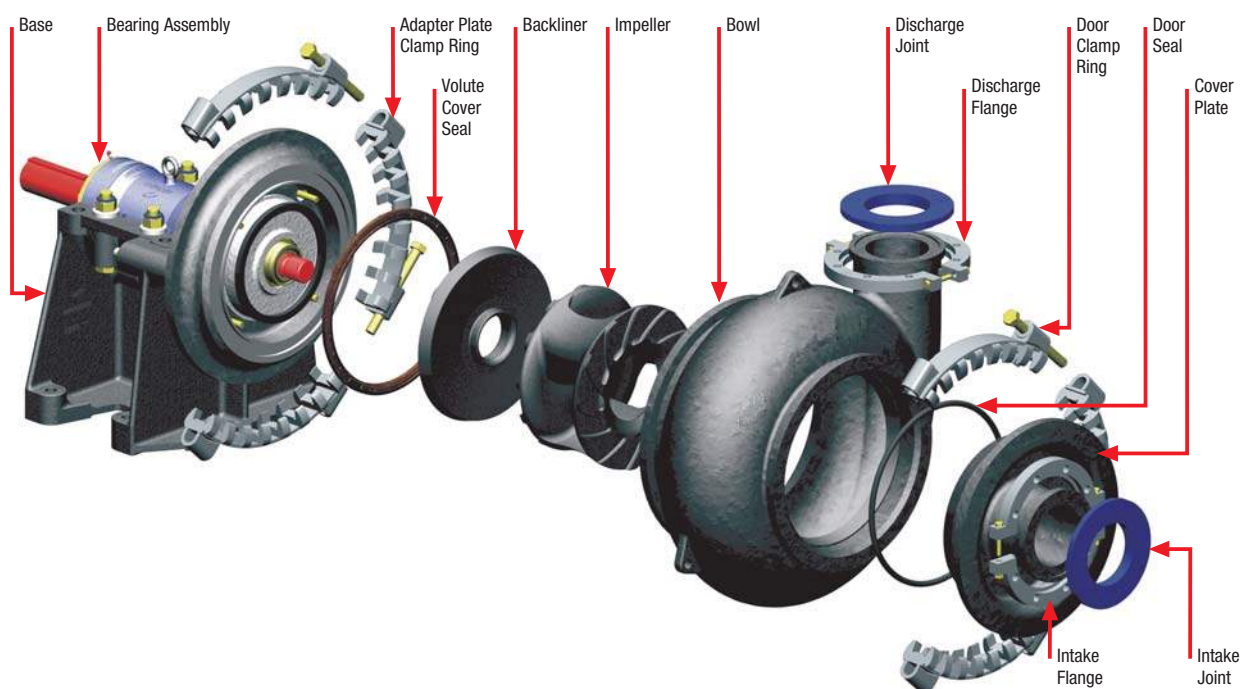

Design Application

Application and Versatility

Tobee capability supports an array of customer specifications with products easily adaptable to meet specific process requirements. The TG Gravel sand pump design typically caters for low-medium head high volume duties whereas the TGH Gravel sand pump is best suited to the higher head.

Typical

Dredging

The TG Gravel Sand Pump, is specifically designed for low-medium head duties such as hopper dredging and barge loading.

Sand and Gravel

TGH Heavy Duty Gravel Pump is designed for higher head duties such as cyclone feed, dredging booster, long distance pipelines and high static discharge heads.

Mining Processing

The TG/TGH Heavy Duty Gravel pump range is ideally suited to the extremely abrasive slurries, gravels, stone with big particles in this type of application.



Sugar Beet & Other Root Vegetables

With special impellers designed to prevent damage to the solids the gravel sand pump is widely used for handling Sugar Beet and other vegetable products.

Slag Granulation

Low NPSH requirements and robust design make the Gravel Gravel sand pumps suitable for applications on slurries with higher than normal temperatures.

This is illustrated by their wide use in Slag Granulation plants around the world.

Tunnelling

Severe space limitations and tough operating conditions are normal in tunnelling applications. The Gravel pump's compact design and optional impact resistant cast steel components make it ideally suited for the varied soils and long tunnel lengths that require a pump capable of multi staging on a high flow, high pressure, often surging application.

Tobee TG Pumps: S

Low gland water costs ...

... result from the heavy shaft and reduced deflection which allow the use of a close tolerance lantern restrictor which reduces the quantity and therefore the cost of gland water..

An easily removable shaft sleeve ...

... manufactured in either hardened steel or ceramic coated steel with o-ring seals at both ends protects the shaft from abrasive or corrosive contaminants.

Simple impeller removal ...

... on large sizes of pump is achieved by the use of a split release collar on the bearing side of the shaft sleeve.

Extended bearing life ...

... is achieved through the use of a large diameter shaft with the shortest possible overhang, with heavy duty roller bearings housed in a removable bearing cartridge.

No oil recirculation pump ...

... is required as the heavy duty grease lubricated taper roller bearings carry all radial loads with unusually high service factors even at maximum speed.

Simple impeller adjustment ...

... is achieved using a very robust one piece casting that cradles the bearing cartridge assembly with a conveniently located adjustment facility. It also supports the pump wet end using a minimum number of through bolts.

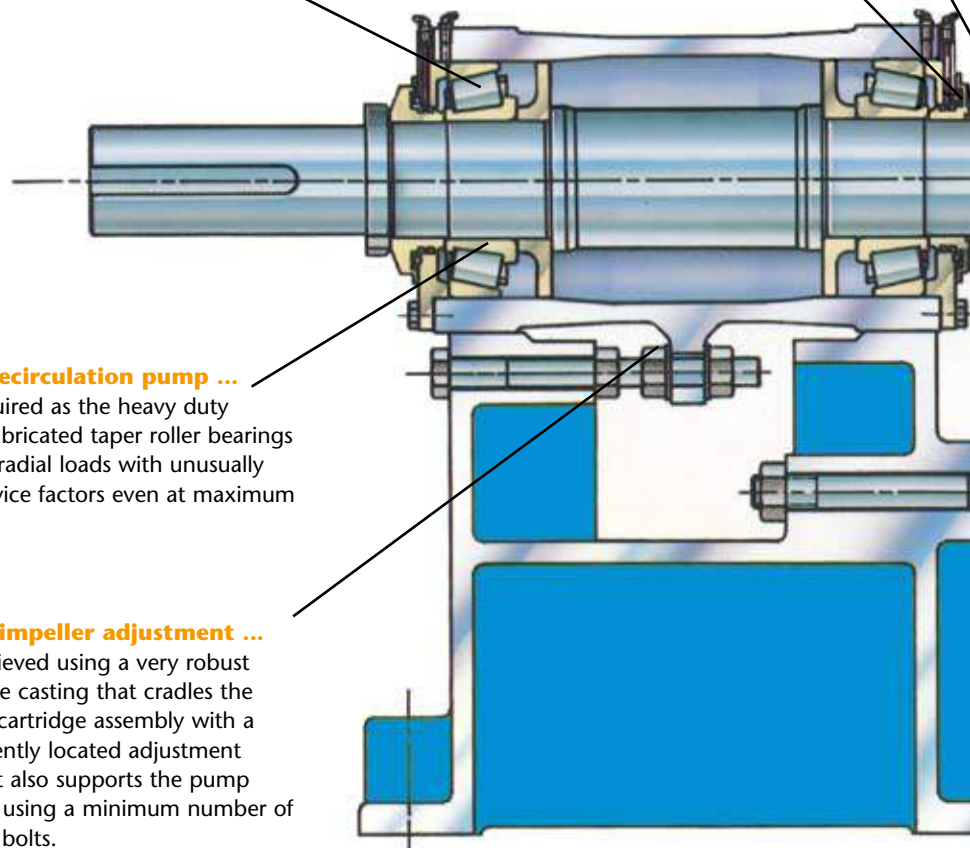

Structure Features

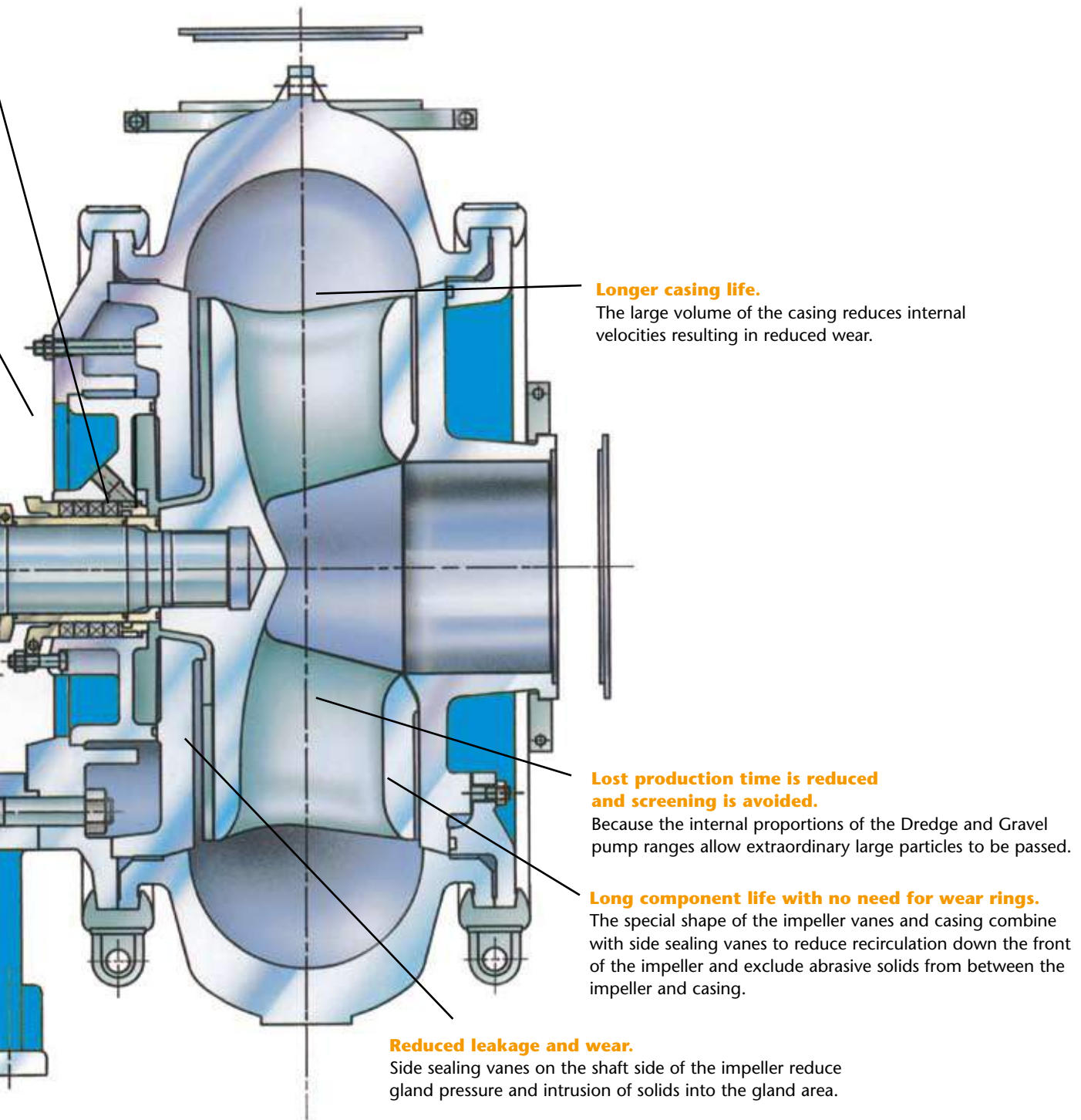

Tobee TG Series Mo

Quick selection chart

Tobee Gravel Sand Pumps - Quick Selection Chart
Approximate clear water performance - to be used as a first guide only

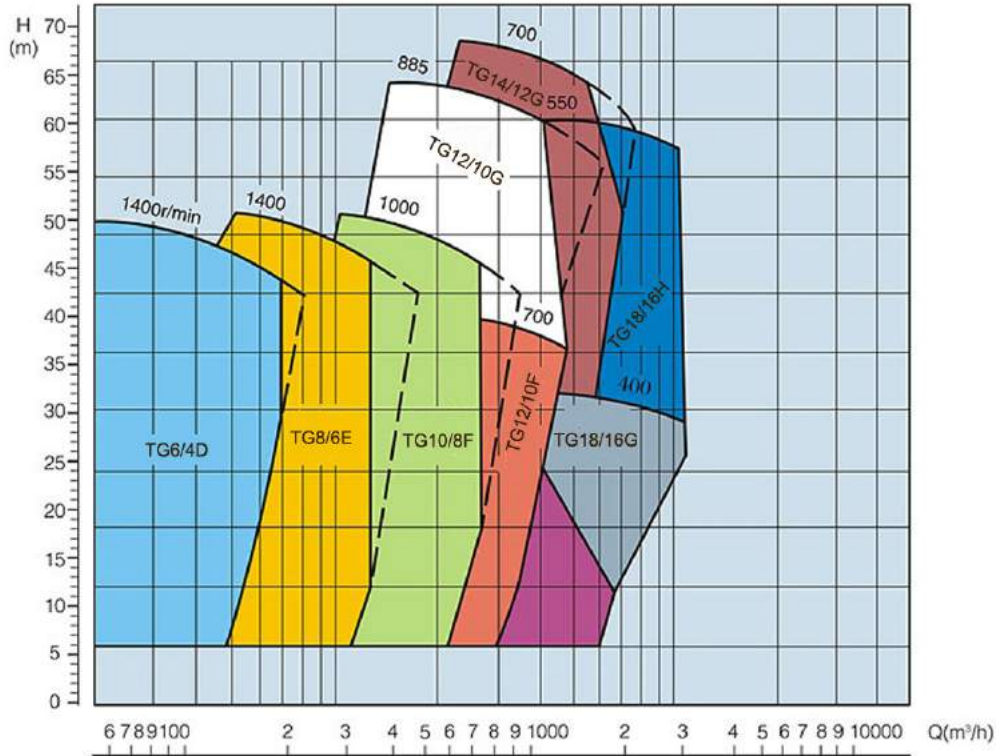

Performance parameters

MODEL	MAX. POWER P	CAPACITY Q	HEAD H	SPEED N	EFFICIENCY	NPSH	IMPELLER DIA.
	(kw)	(m ³ /h)	(m)	(rpm)	(%)	(m)	(mm)
TG6/4D	60	36-250	5-52	600-1400	58	2-5.5	378
TG8/6E	120	126-576	6-45	800-1400	60	3-4.5	391
TG10/8S	560	216-936	8-52	500-1000	65	3-7.5	533
TGH10/8S	560	180-1440	24-80	500-950	72	2.5.5	711
TG10/8F	600	216-936	8-52	400-800	65	3-7.5	533
TG12/10F	600	360-1440	10-60	350-700	65	1.5-4.5	667
TG12/10G	600	288-1440	10-60	400-850	65	1.5-4.5	667
TGH12/10G	600	288-2808	16-80	350-700	73	2-10	950
TG14/12G	600	576-3024	8-70	300-700	68	2-8	864
TG14/12T	1200	576-3024	8-70	300-700	68	2-8	864
TG16/14G	600	720-3600	18-45	300-500	70	3-9	1016
TGH16/14TU	1200	324-3600	26-70	300-500	72	3-6	1270
TG18/16TU	1200	720-4320	12-48	250-500	72	3-6	1067

Models and Dimensions

Dimensional Drawing

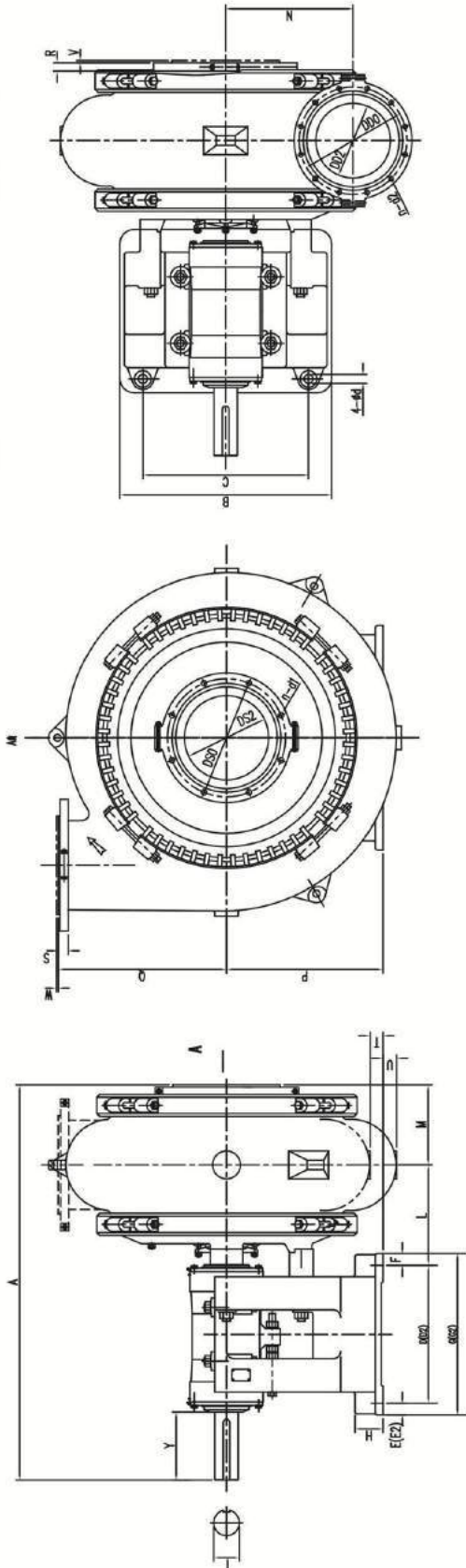

Model	Baseplate dimensions														Foot										Pump dimensions										Clearance				Suction Flange				Discharge Flange				Weight (kg)
	A	B	C	D	E	F	G	D2	E2	G2	H	I	n-d	L	M	N	P	Q	R	S	T	U	V	W	DS0	DS2	n-d1	DD0	DD2	n-d2																	
TG6/4D	1006	492	432	213	38	75	289	NUL	NUL	NUL	54	65	4-22	330	203	260	330	343	33	32	16	NUL	8	5	305	260	8-19	254	210	4-19	460																
TG8/6E	1286	622	546	257	54	83	365	NUL	NUL	NUL	75	80	4-29	392	295	352	457	405	29	29	54	NUL	6	8	368	324	8-19	305	260	8-19	1120																
TG10/8F	1591	857	762	349	45	45	540	NUL	NUL	NUL	98	100	4-35	487	330	416	610	533	48	41	60	NUL	8	6	457	406	8-22	368	324	8-19	2250																
TG10/8S	1720	920	760	NUL	NUL	NUL	640	70	780	90	90	120	4-35	378	330	416	450	533	48	41	NUL	102	8	6	457	406	8-22	368	324	8-19	2285																
TG12/10G	2010	1207	851	NUL	NUL	NUL	749	64	876	152	152	140	4-41	473	368	522	851	665	48	49	238	NUL	10	8	527	470	12-22	457	406	8-22	4450																
TG14/12G	2096	1207	851	NUL	NUL	NUL	749	64	876	152	152	140	4-41	502	424	610	851	787	48	48	121	NUL	8	10	552	495	8-22	527	470	12-22	5400																
TGH10BS	1774	920	760	NUL	NUL	NUL	640	70	780	90	90	120	4-35	455	330	475	450	620	48	42	NUL	206	8	6	457	406	8-22	368	324	8-19	3188																
TGH12/10G	2062	1219	851	NUL	NUL	NUL	749	64	876	152	152	140	4-41	496	400	605	851	800	60	60	40	NUL	10	8	533	476	8-29	483	432	8-25	4638																
TGH18/14G	2367	1460	1200	NUL	NUL	NUL	860	95	1050	150	150	150	4-79	649	448	765	900	1008	72	82	NUL	120	8	10	650	600	12-28	600	540	12-28	12247																

Note: The length unit is millimeter (mm).

Tobee Products



Horizontal Pumps

The Tobee horizontal pump provide a comprehensive range of centrifugal slurry pumps for use in mining, chemical and dredging or industrial applications.



Vertical Pumps

The Tobee Vertical pumps provide a simple yet rugged range of sump pumps specially developed for rugged cleanup and abrasive slurry applications.



Submersible Pumps

The Tobee Submersible pumps provide heavy duty all chrome wet end coupled with a submersible motor designed for the most demanding applications.



Metal Parts



Rubber Parts



Polyurethane Parts

HEBEI TOBEE PUMP CO.,LIMITED

No. 266, Tianshan St,
High-tech Zone,
Shijiazhuang City
050000, China.

Tel.: +86 18032034573
Fax.:+86-0311-87221317
Email: Sales@tobeeump.com
Web: ww.tobeeump.com



Always do your best pump®