

# Transformation of Shapes

Recognize how each shape has transformed. Write translation, reflection or rotation.

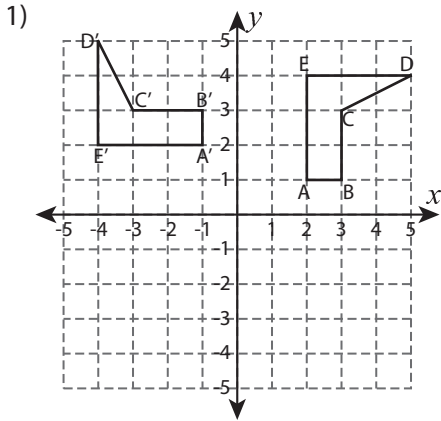

\_\_\_\_\_

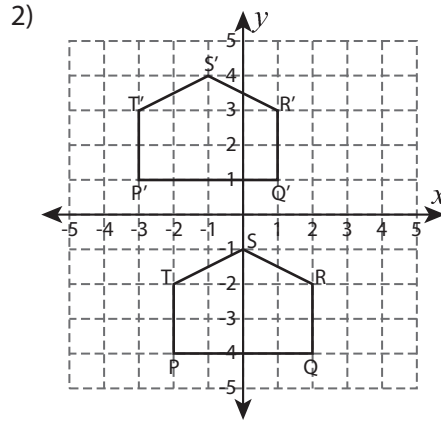

\_\_\_\_\_

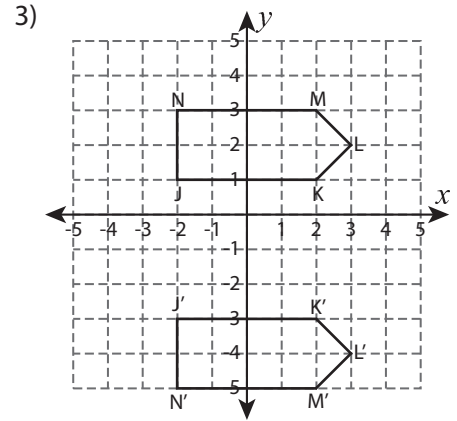

\_\_\_\_\_

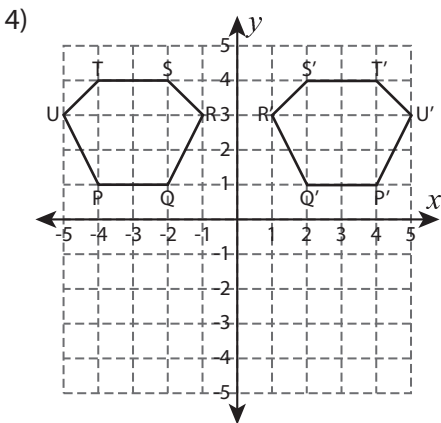

\_\_\_\_\_

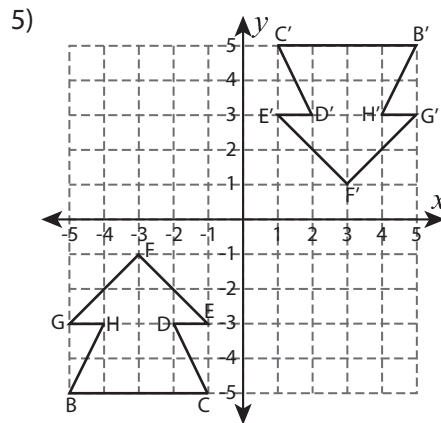

\_\_\_\_\_

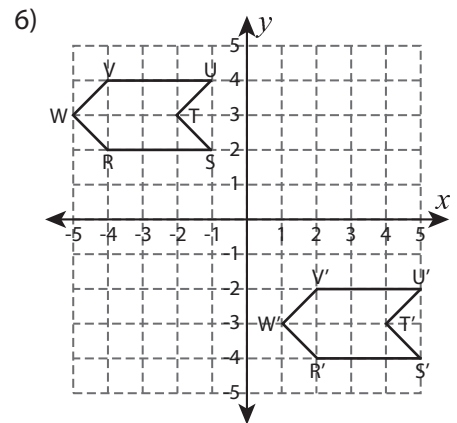

\_\_\_\_\_

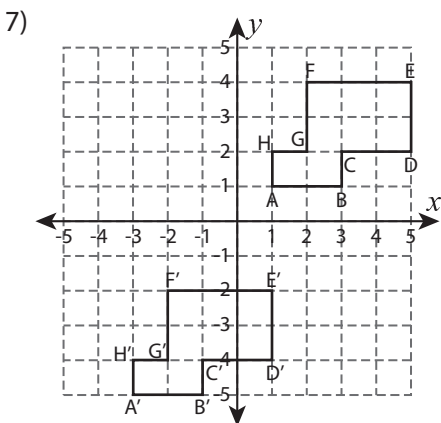

\_\_\_\_\_

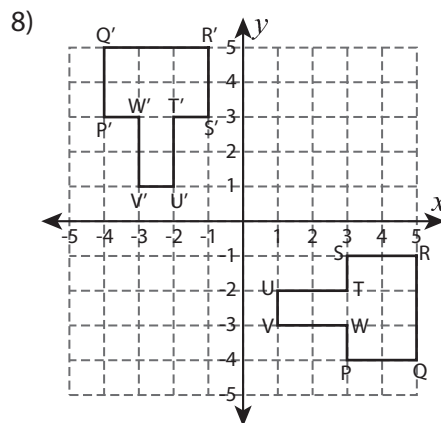

\_\_\_\_\_

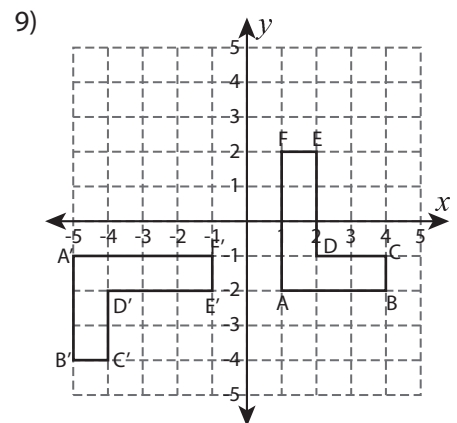

\_\_\_\_\_

## Translation of Quadrilaterals

Sheet 2

Graph the image of each quadrilateral using the translation given.

1) 2 units right and 3 units down

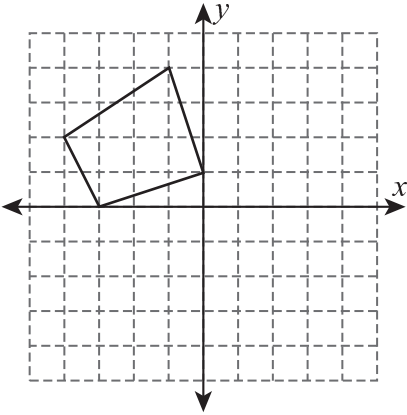

2) 5 units left and 7 units up

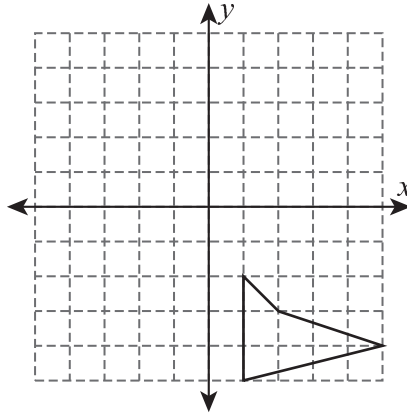

3) 4 units down and 2 units left

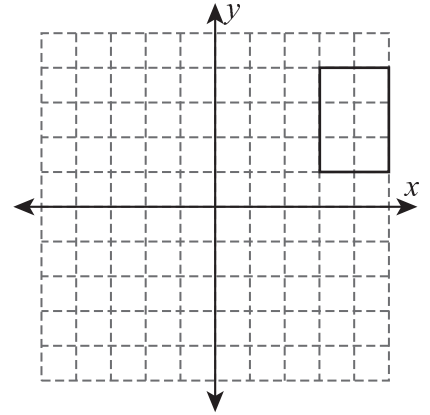

4) 1 unit up and 7 units left

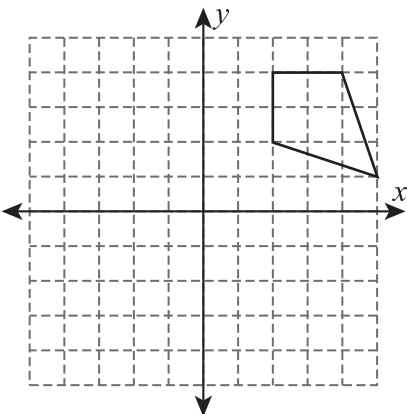

5) 8 units down and 6 units right

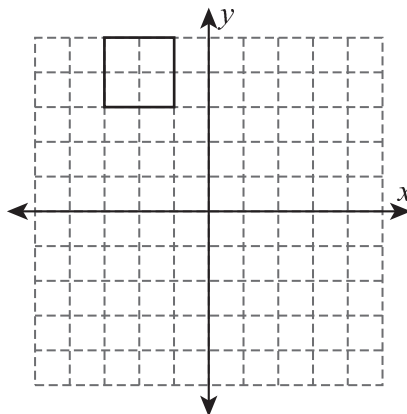

6) 1 unit left and 5 units down

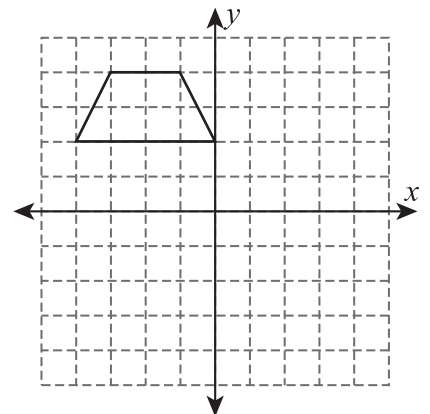

7) 6 units left and 2 units up

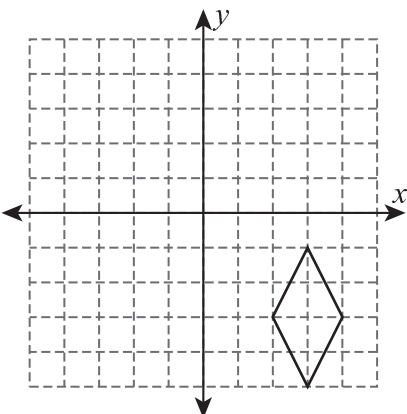

8) 3 units right and 8 units up

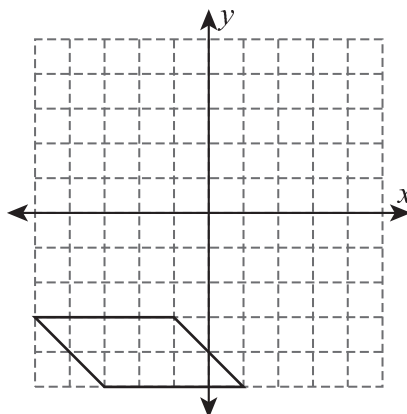



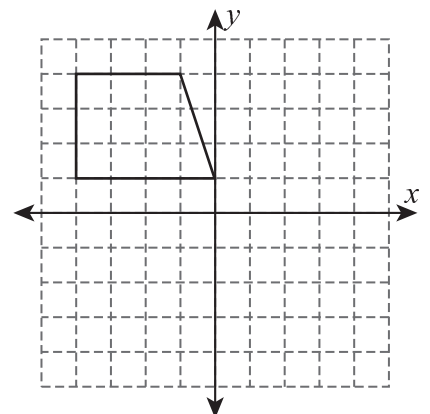





























9) 4 units right



## Rotation of Shapes - Multiple Choice

Sheet 1

- 1) Which one of the following is a  $90^\circ$  clockwise rotation of  about the origin?
- a)       b)       c) 
- 2) Which one of the following is a  $90^\circ$  counterclockwise rotation of  about the origin?
- a)       b)       c) 
- 3) Which one of the following is a  $180^\circ$  rotation of  about the origin?
- a)       b)       c) 
- 4) Which one of the following is a  $90^\circ$  counterclockwise rotation of  about the origin?
- a)       b)       c) 
- 5) Which one of the following is a  $180^\circ$  rotation of  about the origin?
- a)       b)       c) 
- 6) Which one of the following is a  $90^\circ$  clockwise rotation of  about the origin?
- a)       b)       c) 
- 7) Which one of the following is a  $90^\circ$  counterclockwise rotation of  about the origin?
- a)       b)       c) 
- 8) Which one of the following is a  $90^\circ$  clockwise rotation of  about the origin?
- a)       b)       c) 

## Reflect the Shapes

Sheet 3

Graph the image of each shape after the given reflection.

- 1) Reflection across the line
- $x = -4$

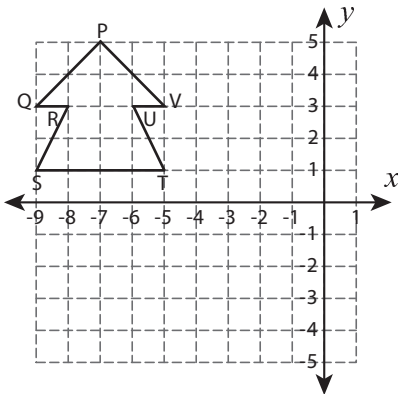

- 2) Reflection across the line
- $y = 1$

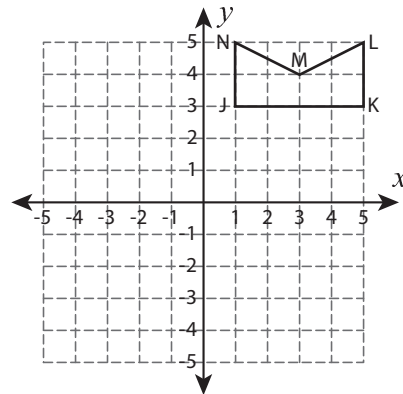

- 3) Reflection across the y-axis

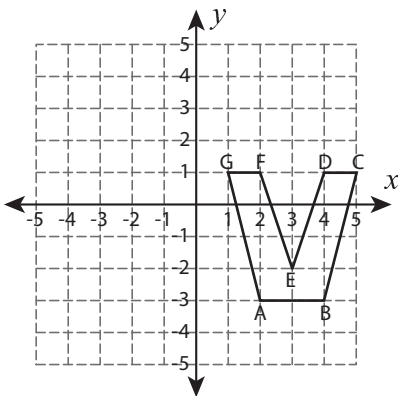

- 4) Reflection across the line
- $x = 6$

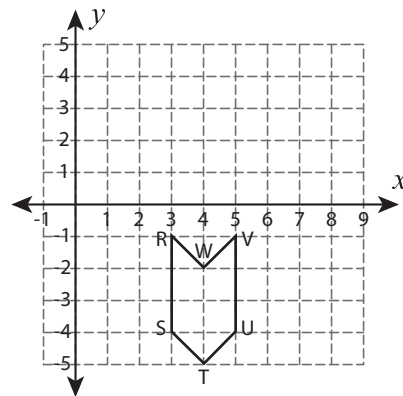

- 5) Reflection across the line
- $x = -1$

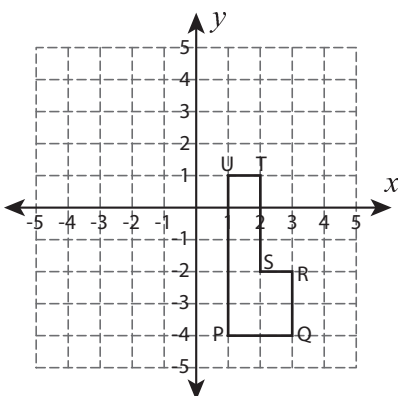

- 6) Reflection across the line
- $y = -5$

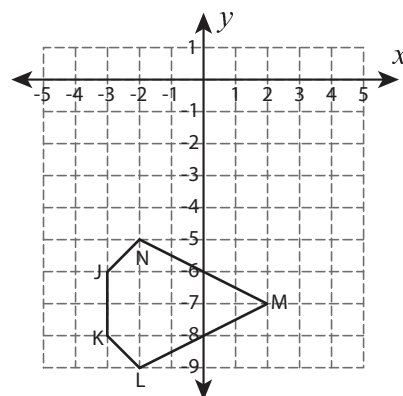

- 7) Reflection across the line
- $y = 3$

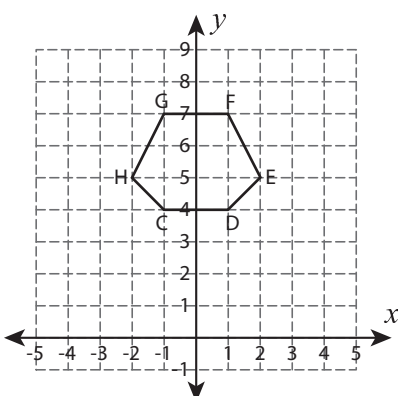

- 8) Reflection across the line
- $x = -2$

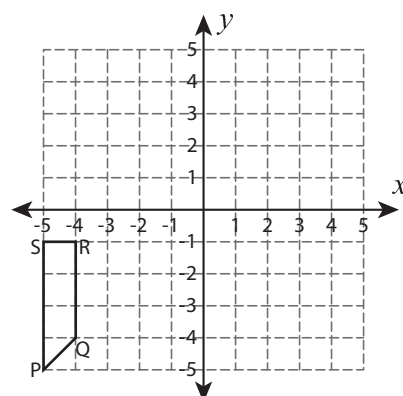

**Transform the Shapes**

Sheet 1

Graph the image of each shape after the given transformation.

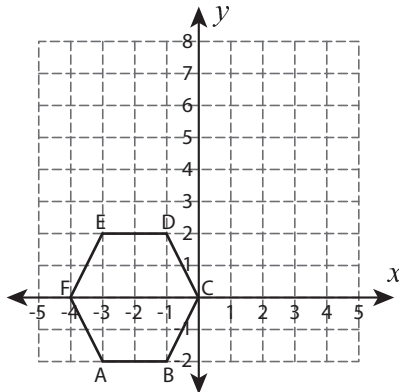
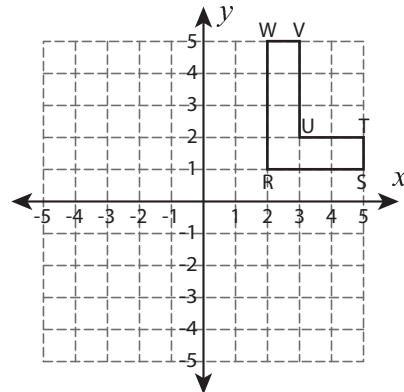
1) Reflection across the line  $y = 3$ 2)  $90^\circ$  counterclockwise rotation about the origin

3) Translate 6 units up and 4 units left

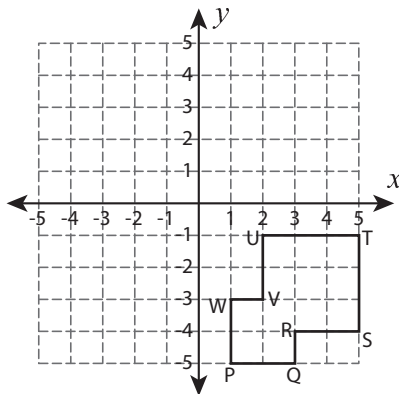
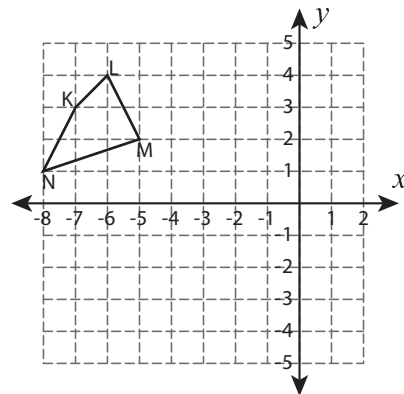
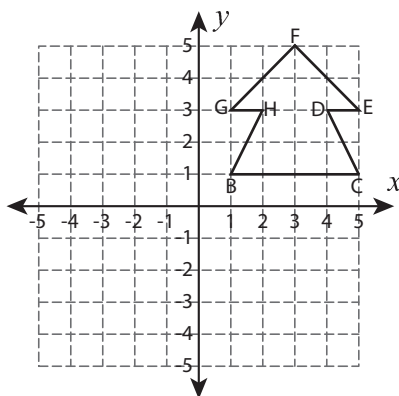
4) Reflection across the line  $x = -4$ 5)  $180^\circ$  rotation about the origin

6) Translate 5 units right and 3 units down

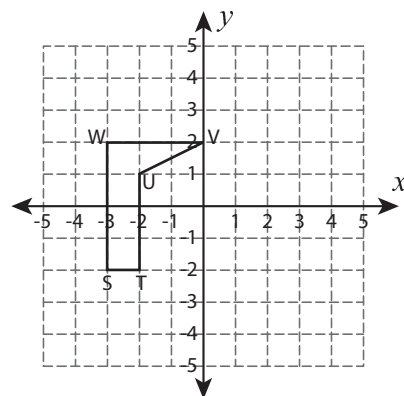

7) Reflection across the x-axis

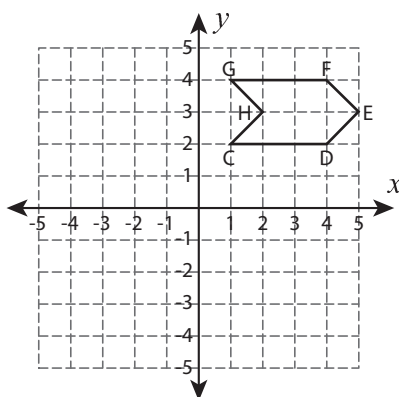
8)  $90^\circ$  clockwise rotation about the origin